

Important: (1) Normal maintenance and adjustments to the product is the responsibility of the customer. (2) Normal wear and tear is not covered under warranty. (3) Rubber/plastic parts and consumables such as blades, clutch and clutch-bell, spark-plugs, nylon line, air-filters, fuel-filters, oil seals etc. are not covered under the warranty.

No Warranty On Electrical Motor / Electrical Parts / Battery Etc.

Incidental / Consequential Loss: KisanKraft Limited or its manufacturers will not be liable for general damages, including bodily injuries, or for incidental or consequential damages including, but not limited to, loss of use, loss of profits, loss of production, expense of substitute equipment or other commercial loss or damage.

Limitation of Liability: This limited warranty is in lieu of all other express warranties, obligations, or liabilities. Any implied warranties, obligations or liabilities, including, but not limited to, any implied warranty of merchantability shall be limited in duration to the applicable warranty period. Any action for breach of any warranty hereunder, including, but not limited to, any implied warranty of merchantability must be brought within the applicable warranty period.

Modifications of Warranty: No agent, representative, dealer, or employee of KisanKraft Limited or any of its manufacturers has the authority to increase or alter the obligations of this warranty.

Assignment / Transfer of warranty: The warranty cannot be assigned and shall not transfer if the product is resold by the first buyer. The above warranties are extended to the first end user (original purchaser), and no warranty is made, nor authorized to be made assignable on resale by the first end user.

What you must do to obtain limited warranty service: To obtain performance of any obligation under this warranty for failure during the applicable warranty period, deliver the defective product, to the nearest Authorized Dealer. KisanKraft Limited, its manufacturers and its dealers reserve the right to inspect the claimed defective part(s) to determine if the malfunction is the result of a defect covered by this warranty. Please note that the decision of KisanKraft Limited with respect to any warranty claim is final.

Receipt is required for availing warranty services

Jurisdiction: All disputes are subject to Bangalore court's jurisdiction.

Our Products

- ◆Chainsaws◆Brush Cutters and Accessories◆Harvesters◆
- ◆Engines and Water Pumps◆Hand Tools◆Garden Tools◆
- ◆Cultivators and Accessories◆Sprayers and Accessories◆
- ◆Transplanter and Post Hole Digger ◆Milking Machines◆

This warranty is null & void, if you fail to register the warranty with KisanKraft by sending the KisanKraft Copy with dealer's stamp.

KisanKraft Limited (formerly known as KisanKraft Machine Tools P Ltd)

🌐: www.kisankraft.com ✉: info@kisankraft.com ☎: +91.80.22178200

Product	Agricultural Inter-Cultivator	KisanKraft Invoice Date	
Brand	KisanKraft	KisanKraft Invoice No.	
Model	<input type="checkbox"/> KK-IC-100P <input type="checkbox"/> KK-IC-105P <input type="checkbox"/> KK-IC-200P	<input type="checkbox"/> KK-IC-205P <input type="checkbox"/> KK-IC-207P	
WARRANTY PERIOD	6 MONTHS	FOR THE SPECIFIED PERIOD FROM THE DATE OF SALE OR DELIVERY WHICHEVER IS EARLIER.	
Dealer's Invoice Date		Dealer's Invoice No.	
Buyer's Info (Name, Address, Phone, etc.):		Dealer's Stamp (Address, Phone, TIN, etc.):	
Buyer's Sign		Dealer's Sign	

What is covered: KisanKraft Limited and its manufacturers warrant this product to be free from defects in material or workmanship. All parts defective in material and workmanship are covered.

This warranty will only cover defects arising under normal usage.

This warranty is limited to repair or replacement by KisanKraft Limited or its manufacturers at the premises of Authorized Dealers, of such parts as appear to KisanKraft or its manufacturers, upon inspection, to be defective in material and/or workmanship. KisanKraft or its manufacturers make no warranty with respect to trade accessories not manufactured or sold by them.

What is not covered: The *warranty shall become null and void* and neither KisanKraft Limited nor any of its manufacturers, nor its authorized dealers assumes any responsibility, if the failure was caused by the following:

- (1) Operation of product with incorrect fuel or lubricants,
- (2) Incorrect usage of machine or misuse,
- (3) Lack of maintenance,
- (4) Negligence,
- (5) Accident or physical damage,
- (6) Repairs made by unauthorized parties and/or with unauthorized parts,
- (7) Improper set up, adjustments, tampering or altered products

Note: *The purchase is not contingent upon a product demonstration. The purchaser shall satisfy himself with the product, including any product demonstration or verification of any function, before buying. KisanKraft Limited or its authorized dealers, including online sellers, shall not be liable to give any on-site demonstration after purchase of any of the product.*

This warranty is null & void, if you fail to register the warranty with KisanKraft by sending the KisanKraft Copy with dealer's stamp.

KisanKraft Limited (formerly known as KisanKraft Machine Tools P Ltd)

🌐: www.kisankraft.com ✉: info@kisankraft.com ☎: +91.80.22178200

Important: (1) Normal maintenance and adjustments to the product is the responsibility of the customer. (2) Normal wear and tear is not covered under warranty (3) Rubber/plastic parts and consumables such as blades, clutch and clutch-bell, spark-plugs, nylon line, air-filters, fuel-filters, oil seals etc. are not covered under the warranty.

No Warranty On Electrical Motor / Electrical Parts / Battery Etc.

Incidental / Consequential Loss: KisanKraft Limited or its manufacturers will not be liable for general damages, including bodily injuries, or for incidental or consequential damages including, but not limited to, loss of use, loss of profits, loss of production, expense of substitute equipment or other commercial loss or damage.

Limitation of Liability: This limited warranty is in lieu of all other express warranties, obligations, or liabilities. Any implied warranties, obligations or liabilities, including, but not limited to, any implied warranty of merchantability shall be limited in duration to the applicable warranty period. Any action for breach of any warranties hereunder, including, but not limited to, any implied warranty of merchantability must be brought within the applicable warranty period.

Modifications of Warranty: No agent, representative, dealer, or employee of KisanKraft Limited or any of its manufacturers has the authority to increase or alter the obligations of this warranty.

Assignment / Transfer of warranty: The warranty cannot be assigned and shall not transfer if the product is resold by the first buyer. The above warranties are extended to the first end user (original purchaser), and no warranty is made, nor authorized to be made assignable on resale by the first end user.

What you must do to obtain limited warranty service: To obtain performance of any obligation under this warranty for failure during the applicable warranty period, deliver the defective product, to the nearest Authorized Dealer. KisanKraft Limited, its manufacturers and its dealers reserve the right to inspect the claimed defective part(s) to determine if the malfunction is the result of a defect covered by this warranty. Please note that the decision of KisanKraft Limited with respect to any warranty claim is final.

Receipt is required for availing warranty services

Jurisdiction: All disputes are subject to Bangalore court's jurisdiction.

Our Products	<ul style="list-style-type: none"> ◆Chainsaws◆Brush Cutters and Accessories◆Harvesters◆ ◆Engines and Water Pumps◆Hand Tools◆Garden Tools◆ ◆Cultivators and Accessories◆Sprayers and Accessories◆ ◆Transplanter and Post Hole Digger ◆Milking Machines◆
---------------------	--------------------------------------------------------------------------------------------------------------------------------------------------------------------------------------------------------------------------------------------------------------------------------------------------

This warranty is null & void, if you fail to register the warranty with KisanKraft by sending the KisanKraft Copy with dealer's stamp. KisanKraft Limited (formerly known as KisanKraft Machine Tools P Ltd)

Product	Agricultural Inter-Cultivator	KisanKraft Invoice Date	
Brand	KisanKraft	KisanKraft Invoice No.	
Model	<input type="checkbox"/> KK-IC-100P <input type="checkbox"/> KK-IC-105P <input type="checkbox"/> KK-IC-200P	<input type="checkbox"/> KK-IC-205P <input type="checkbox"/> KK-IC-207P	
WARRANTY PERIOD	6 MONTHS	FOR THE SPECIFIED PERIOD FROM THE DATE OF SALE OR DELIVERY WHICHEVER IS EARLIER.	
Dealer's Invoice Date		Dealer's Invoice No.	
Buyer's Info (Name, Address, Phone, etc.):		Dealer's Stamp (Address, Phone, TIN, etc.):	
Buyer's Sign		Dealer's Sign	

What is covered: KisanKraft Limited and its manufacturers warrant this product to be free from defects in material or workmanship. All parts defective in material and workmanship are covered.

This warranty will only cover defects arising under normal usage.

This warranty is limited to repair or replacement by KisanKraft Limited or its manufacturers at the premises of Authorized Dealers, of such parts as appear to KisanKraft or its manufacturers, upon inspection, to be defective in material and/or workmanship. KisanKraft or its manufacturers make no warranty with respect to trade accessories not manufactured or sold by them.

What is not covered: The warranty shall become null and void and neither KisanKraft Limited nor any of its manufacturers, nor its authorized dealers assumes any responsibility, if the failure was caused by the following:

- (1) Operation of product with incorrect fuel or lubricants,
- (2) Incorrect usage of machine or misuse,
- (3) Lack of maintenance,
- (4) Negligence,
- (5) Accident or physical damage,
- (6) Repairs made by unauthorized parties and/or with unauthorized parts,
- (7) Improper set up, adjustments, tampering or altered products

Note: The purchase is not contingent upon a product demonstration. The purchaser shall satisfy himself with the product, including any product demonstration or verification of any function, before buying. KisanKraft Limited or its authorized dealers, including online sellers, shall not be liable to give any on-site demonstration after purchase of any of the product.

This warranty is null & void, if you fail to register the warranty with KisanKraft by sending the KisanKraft Copy with dealer's stamp. KisanKraft Limited (formerly known as KisanKraft Machine Tools P Ltd)



Wide Range of Products for Every Need



For more information give **MISSED CALL: 07676065555**



Many of our products have BIS: ISI certification.



User Manual



KK-IC-200P/205P



KK-IC-100P

KisanKraft Limited

(Formerly known as KisanKraft Machine Tools Pvt. Ltd)

Sri Huchhanna Tower, #4, 1st Main, 7-A Cross, Maruthi Layout, Dasarahalli,
 HAF Post, Hebbal, Bangalore 560024, Karnataka, INDIA

- ◆ Bangalore (HO) ◆ Ahmedabad ◆ Bhopal ◆ Bhubaneswar ◆
- ◆ Coimbatore ◆ Guwahati ◆ Shimla ◆ Hubli ◆ Hyderabad ◆
- ◆ Jaipur ◆ Karnal ◆ Kolkata ◆ Lucknow ◆ Jammu ◆ Pune ◆ Raipur ◆

CONTENTS

BEFORE GETTING STARTED..... 7

APPLICATION 7

SAFETY INSTRUCTIONS..... 7

PRODUCT OVERVIEW10

ASSEMBLY11

OPERATION CHECK.....13

STARTING THE ENGINE.....17

INTER-CULTIVATOR OPERATION18

STOPPING THE ENGINE21

MAINTENANCE22

TRANSPORTATION AND STORAGE.....26

TECHNICAL SPECIFICATIONS28

TROUBLESHOOTING30

PARTS DIAGRAM & LIST-BODY-(KK-IC-200P)33

OPERATION MANUAL44

ENGINE PARTS DIAGRAM & LIST- KK – PE4 - 20353

KisanKraft has a large range of products to serve the farmers. A list of our products is given below:

<p>Brush Cutters and Accessories</p> <ul style="list-style-type: none"> Brush Cutter/Power Weeder Backpack Brush Cutter Tea Pruner Pole pruner with Engine Reaper Attachment Blades-Circular Blades (2 & 3 points) Baffle Nylon Rope Tap & Go <p>Chainsaws</p> <ul style="list-style-type: none"> Petrol Chainsaw Electric Chainsaw Chain Sharpening Machine <p>Engines and Water Pumps</p> <ul style="list-style-type: none"> Engine –Diesel-(Horizontal) Engine –Diesel(Vertical) Engine-Kerosene Water Pump with Petrol Engine Water Pump with Kerosene Engine Water Pump with Diesel Engine <p>Hand Tools</p> <ul style="list-style-type: none"> Secateurs Folding Saw Garden Rake Garden Shovel Hedge Shear Lopper Telescopic Hedge Shear Telescopic Lopping Shear Tree Pruner Telescopic Steel Pipe & Fruit Picker Bag Sheep Shear <p>Garden Tools</p> <ul style="list-style-type: none"> Electric Pressure Washer Hedge Trimmer Lawn Mower (Electric, Petrol & Manual) Leaf Blower 	<p>Cultivators and Accessories</p> <ul style="list-style-type: none"> Petrol and Diesel <p>Sprayers and Accessories</p> <ul style="list-style-type: none"> Battery Sprayer Portable Power Sprayer Trolley Sprayer Manual Knapsack Sprayer Manual Pressure Sprayer Rose Cans Hose Crimping Machine HTP Sprayer HTP Delivery Hose HTP Hose Reel HTP Stand HTP Gun / Lance(Brass Rod Knapsack Power Sprayer Mister / Duster / Granuel Spreader HTP Sprayer Set with Diesel Engine HTP Sprayer Set with Kerosene Engine Fogging Machine <p>Milking Machine</p> <ul style="list-style-type: none"> Wood Shredder Fodder Ensiling Chaff Cutter Fodder Grinder Chaff Cutter Fodder Mini Chaff Cutter <p>Harvester</p> <ul style="list-style-type: none"> Maize Sheller Maize Sheller + Dehusker Maize Combine Harvester Onion Digger Carlotti Italy Tea Leaf Harvester Sugarcane Combine Harvester Sugarcane Leaf Stripper <p>Transplanter and Post Hole Digger</p> <ul style="list-style-type: none"> Paddy Transplanter (2 & 8 Rows) Transplanter-Vegetable & Tobacco Post Hole Digger(4" to 14" Augers)
----------------------------------------------------------------------------------------------------------------------------------------------------------------------------------------------------------------------------------------------------------------------------------------------------------------------------------------------------------------------------------------------------------------------------------------------------------------------------------------------------------------------------------------------------------------------------------------------------------------------------------------------------------------------------------------------------------------------------------------------------------------------------------------------------------------------------------------------------------------------------------------------------------------------------------------------------------------------------------------------------------------------------------------------------------------------------------------------------------------------------------------------------------------------------------------------------------------------------------------------------------------------------------------------------------------------------------------------------------------------------------------------	-------------------------------------------------------------------------------------------------------------------------------------------------------------------------------------------------------------------------------------------------------------------------------------------------------------------------------------------------------------------------------------------------------------------------------------------------------------------------------------------------------------------------------------------------------------------------------------------------------------------------------------------------------------------------------------------------------------------------------------------------------------------------------------------------------------------------------------------------------------------------------------------------------------------------------------------------------------------------------------------------------------------------------------------------------------------------------------------------------------------------------------------------------------------------------------------------------------------------------------------------------------------------------------------------------------------------------------------------------------------------------------------------------------------------------------------------------------------------------

SL-No	KK-No	KK-Name	Qty
4	E15-04	Gasket Fuel tank Cap	1
5	E15-05	Fuel tank	1
6	E15-06	Fuel Filter	1
7	E15-07	Fuel Tube M4.5x140	1
8	E15-08	Clip Fuel tube	2
9	E15-09	O-ring 14mm(Fuel outlet joint)	1
10	E15-10	Nut M6 Flanged	2
11	E15-11	Bolt M6x30 Flanged Hex	1

Product	Agricultural Inter-Cultivator	KisanKraft Invoice Date	
Brand	KisanKraft	KisanKraft Invoice No.	
Model	<input type="checkbox"/> KK-IC-100P <input type="checkbox"/> KK-IC-105P <input type="checkbox"/> KK-IC-200P	<input type="checkbox"/> KK-IC-205P <input type="checkbox"/> KK-IC-207P	
WARRANTY PERIOD	6 MONTHS	FOR THE SPECIFIED PERIOD FROM THE DATE OF SALE OR DELIVERY WHICHEVER IS EARLIER.	
Dealer's Invoice Date		Dealer's Invoice No.	
Buyer's Info (Name, Address, Phone, etc.):		Dealer's Stamp (Address, Phone, TIN, etc.):	
Buyer's Sign		Dealer's Sign	

What is covered: KisanKraft Limited and its manufacturers warrant this product to be free from defects in material or workmanship. All parts defective in material and workmanship are covered.

This warranty will only cover defects arising under normal usage.

This warranty is limited to repair or replacement by KisanKraft Limited or its manufacturers at the premises of Authorized Dealers, of such parts as appear to KisanKraft or its manufacturers, upon inspection, to be defective in material and/or workmanship. KisanKraft or its manufacturers make no warranty with respect to trade accessories not manufactured or sold by them.

What is not covered: The *warranty shall become null and void* and neither KisanKraft Limited nor any of its manufacturers, nor its authorized dealers assumes any responsibility, if the failure was caused by the following:

- (1) Operation of product with incorrect fuel or lubricants,
- (2) Incorrect usage of machine or misuse,
- (3) Lack of maintenance,
- (4) Negligence,
- (5) Accident or physical damage,
- (6) Repairs made by unauthorized parties and/or with unauthorized parts,
- (7) Improper set up, adjustments, tampering or altered products.

Note: The purchase is not contingent upon a product demonstration. The purchaser shall satisfy himself with the product, including any product demonstration or verification of any function, before buying. KisanKraft Limited or its authorized dealers, including online sellers, shall not be liable to give any on-site demonstration after purchase of any of the product.

This warranty is null & void, if you fail to register the warranty with KisanKraft by sending the KisanKraft Copy with dealer's stamp. KisanKraft Limited (formerly known as KisanKraft Machine Tools P Ltd)

Important: (1) Normal maintenance and adjustments to the product is the responsibility of the customer. (2) Normal wear and tear is not covered under warranty. (3) Rubber/plastic parts and consumables such as blades, clutch and clutch-bell, spark-plugs, nylon line, air-filters, fuel-filters, oil seals etc. are not covered under the warranty.

No Warranty On Electrical Motor / Electrical Parts / Battery Etc.

Incidental / Consequential Loss: KisanKraft Limited or its manufacturers will not be liable for general damages, including bodily injuries, or for incidental or consequential damages including, but not limited to, loss of use, loss of profits, loss of production, expense of substitute equipment or other commercial loss or damage. **Limitation of Liability:** This limited warranty is in lieu of all other express warranties, obligations, or liabilities. Any implied warranties, obligations or liabilities, including, but not limited to, any implied warranty of merchantability shall be limited in duration to the applicable warranty period. Any action for breach of any warranty hereunder, including, but not limited to, any implied warranty of merchantability must be brought within the applicable warranty period.

Modifications of Warranty: No agent, representative, dealer, or employee of KisanKraft Limited or any of its manufacturers has the authority to increase or alter the obligations of this warranty.

Assignment / Transfer of warranty: The warranty cannot be assigned and shall not transfer if the product is resold by the first buyer. The above warranties are extended to the first end user (original purchaser), and no warranty is made, nor authorized to be made assignable on resale by the first end user.

What you must do to obtain limited warranty service: To obtain performance of any obligation under this warranty for failure during the applicable warranty period, deliver the defective product, to the nearest Authorized Dealer. KisanKraft Limited, its manufacturers and its dealers reserve the right to inspect the claimed defective part(s) to determine if the malfunction is the result of a defect covered by this warranty. Please note that the decision of KisanKraft Limited with respect to any warranty claim is final.

Receipt is required for availing warranty services

Jurisdiction: All disputes are subject to Bangalore court's jurisdiction.

Our Products	<ul style="list-style-type: none"> ◆Chainsaws◆Brush Cutters and Accessories◆Harvesters◆ ◆Engines and Water Pumps◆Hand Tools◆Garden Tools◆ ◆Cultivators and Accessories◆Sprayers and Accessories◆ ◆Transplanter and Post Hole Digger ◆Milking Machines◆
---------------------	--------------------------------------------------------------------------------------------------------------------------------------------------------------------------------------------------------------------------------------------------------------------------------------------------

This warranty is null & void, if you fail to register the warranty with KisanKraft by sending the KisanKraft Copy with dealer's stamp. KisanKraft Limited (formerly known as KisanKraft Machine Tools P Ltd)

SL-No	KK-No	KK-Name	Qty
1	E14-01	Muffler Assy	1
2	E14-02	N/A	1
3	E14-03	N/A	1
4	E14-04	Screw M5 x 8	4
5	E14-05	N/A	1
6	E14-06	Nut M8	2
7	E14-07	Gasket Muffler	1

Fuel tank

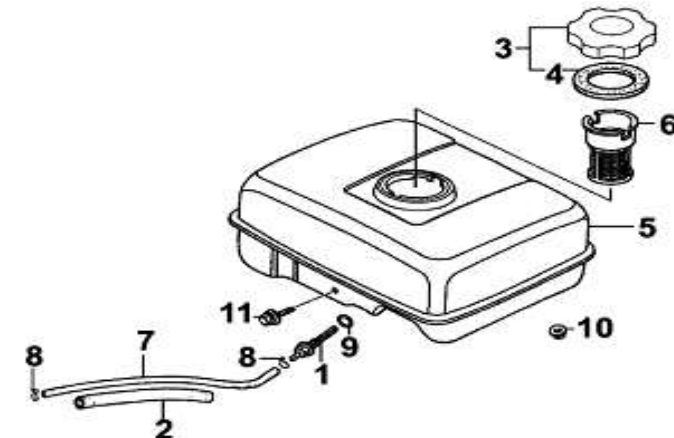

SL-No	KK-No	KK-Name	Qty
1	E15-01	Fuel outlet joint	1
2	E15-02	Sleeve Fuel pipe	1
3	E15-03	Fuel tank cap	1

SL-No	KK-No	KK-Name	Qty
10	E13-10	Butter Fly nut M6	2
11	E13-11	Nut M6	2
12	E13-12	ST Screw M4 x 12	1
13	E13-13	N/A	1
14	E13-14	N/A	1
15	E13-15	N/A	1
16	E13-16	N/A	1
17	E13-17	N/A	1

Muffler

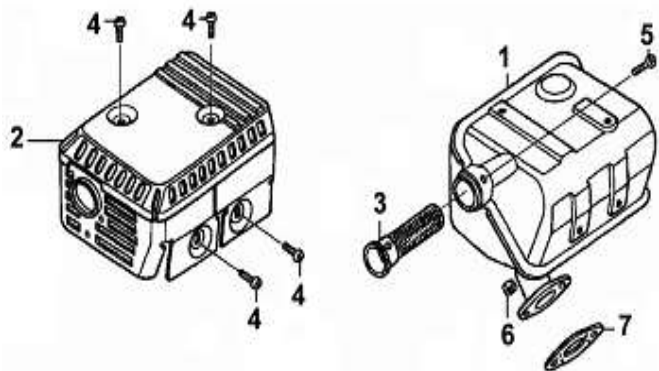

Before Getting Started

Thank you for purchasing our Inter-cultivator.

- This manual contains information on operation and maintenance of the Inter-cultivator, which is based on the most recent product information available at the time of approval for printing. We reserve the right to make amendments without prior notice and without incurring any obligation for sequences.
- No part of this publication may be reproduced without written permission.
- This manual should be considered a permanent part of the cultivator and remain with it if it is resold.
- Please pay special attention to statements preceded by the following words:

 WARNING	Indicates a strong possibility of severe personal injury or death if instructions are not followed.
 CAUTION	Indicates a possibility of personal injury or equipment damage if instructions are not followed.
NOTE	Gives helpful information.

Application

The Inter-cultivator is suitable for cultivating the sandy soil and clay soil of canopied vegetables base, slopes with gradient less than 10%, paddy field with the depth of water surface to hard layer not more than 250mm. For weedy and deep plots, remove the weeds before using the Inter-cultivator to cultivate the land. Assemble blades on both side of tilling system, and use pin to fixed blades to do tilling work. Take off resistance rod and assemble ditching blade, for ditching work.

Safety Instructions

Important:

- When the engine is starting, turn the shift lever to the “Neutral Position” .
- Be careful when tiller is working.
- Check the blades.
- The fuel and oil must be suitable and clean.
- Release clutch before gear shifting and slow down the engine. It is safer when engine is slow down.
- Fuel is easy to catch fire and exploded.
- When working in paddy field or on a slope, use the reverse gear carefully.



- This Inter-cultivator is designed to give safe and dependable service if operated according to the instructions.
- Read and understand the Operation Manual before operating the Inter-cultivator. Failure to do so could result in personal injury or equipment damage.



- Exhaust gas contains poisonous carbon monoxide.
- Never run the cultivator in enclosed areas.
- Be sure to provide adequate ventilation during installation and operation.
- The rotating parts are sharp and runs at high speed.
- Accidental contact can cause serious injury. Keep your hands and feet away from the parts while the engine is running.
- Stop the engine and disengage the tines clutch before inspection or maintenance of the tines.
- Disconnect the spark plug cap to prevent any possibility of accidental starting, Wear heavy gloves to protect your hands from the tines when clearing the tines or when inspecting or replacing the tines.



SAFETY LABEL LOCATIONS:

These labels warn you of potential hazards that can cause serious injury. Read the labels and safety notes and precautions described in this manual carefully.



Operator Responsibility:

- Keep the Inter-cultivator in good operating condition. Operating a cultivator in poor or questionable condition could result in serious injury.
- Be sure all safety devices are in working order and warning labels are in place. These items are installed for your safety.
- Make sure that the safety covers (Fan cover, recoil starter cover) are in place.
- Know how to stop the engine and tines quickly in case of emergency.
- Understand the use of all controls.
- Keep a firm hold on the handlebars, they may tend to lift during clutch engagement.
- Don't allow anyone to operate this cultivators without proper training to avoid injury.
- Wear sturdy, fully covered footwear. Operating this Inter-cultivator on barefoot or with open toe shoes or sandals increase your risk of injury.
- Dress sensibly. Loose clothing may be caught by moving parts, increasing your risk of injury.

SL-No	KK-No	KK-Name	Qty
9	E12-09	Nut M14 Fly wheel Assy	1

Air Cleaner

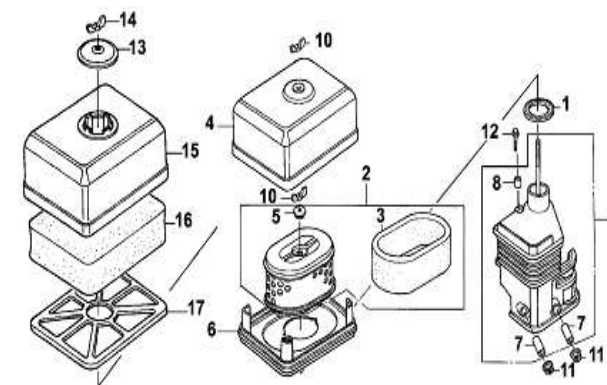

SL-No	KK-No	KK-Name	Qty
	E13	Air Cleaner Assy	1
1	E13-01	Seal Ring 32x47x3	1
2	E13-02	Air Filter Element	1
3	E13-03	N/A	1
4	E13-04	Filter Case	1
5	E13-05	Rubber Fixer	1
6	E13-06	Cover board	1
7	E13-07	N/A	2
8	E13-08	N/A	1
9	E13-09	Air Cleaner Seat Assy	1

SL-No	KK-No	KK-Name	Qty
15	E11-15	N/A	1
16	E11-16	Nut M6 Flanged Nylon	1
17	E11-17	Adjustment Screw	2

Fly Wheel

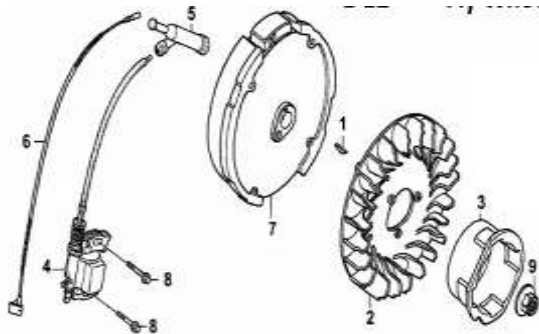

SL-No	KK-No	KK-Name	Qty
1	E12-01	Woodruff key	1
2	E12-02	Fly Wheel Fan	1
3	E12-03	Starter Sleeve	1
4	E12-04	Ignition Coil Assy	1
5	E12-05	Spark Plug Cap	1
6	E12-06	Stop lead	1
7	E12-07	Fly Wheel Assy	1
8	E12-08	Bolt 6 x 25	2

- Always stay alert. Operating this cultivators when you are tired, ill or under the influence of alcohol or drugs may result serious injury.
- Keep all persons and pets away from the tilling area.
- Make sure the drag bar is in place and properly adjusted.

Child Safety:

- Keep children indoors and supervise all the time while any outdoor power equipment is being used nearby. Young children move quickly and are attracted especially by the cultivator and tilling activity.
- Never assume children will remain where you last saw them. Be alert and turn the cultivator off if children enter the area.
- Children should never be allowed to operate the cultivator even under adult supervision.

Thrown Object Hazard:

- Objects hit by the rotating tines can be thrown from the cultivator with great force and may cause severe injury.
- Before tilling clear the tilling area of sticks, large stone wire glass etc.
- Cultivate only in daylight.
- Pieces thrown from worn or damaged-tines can cause serious injury. Always inspect the tines before using the Inter-cultivator.

Fire and Burn Hazard:

- Petrol is extremely flammable and petrol vapor can explode.
- Take extreme care when handling petrol. Keep petrol out of reach of children.
- Refuel in a well-ventilated area with the engine stopped.
- Allow the engine to cool before refueling. Fuel vapor or spilled fuel may be ignited.
- The engine and exhaust system become very hot during operation and remain hot for a while even after stopping. Contact with hot engine components can cause burn injuries and can ignite some materials.
- Avoid touching a hot engine or exhaust system.
- Allow the engine to cool before performing maintenance or storing the cultivator indoors.

Carbon Monoxide Poisoning Hazard:

- Exhaust contains poisonous carbon monoxide a colorless and odorless gas. Breathing exhaust can cause loss of consciousness and may lead to death.
- If you run the engine in an area that is confined or even partially enclosed, the air you breathe could contain a dangerous amount of exhaust gas. To keep exhaust gas from building-up, provide adequate ventilation.

Operation on Slope

- When tilling on slopes, keep the fuel tank less than half full to minimize fuel spillage.
- Till across the slope (At equally spaced intervals) rather than up and down it.

- Be very careful when changing the direction of the cultivator on a slope.
- Do not use the cultivator on a slope for more than 10°.
- The maximum safe grade angle shown is for reference purpose only and should be determined according to the type of the tool. Before starting the engine, check that the Inter-cultivator is not damaged and in good condition. For your safety and safety of others, exercise extreme care when using the Inter-cultivator up or down the hill.

Product Overview

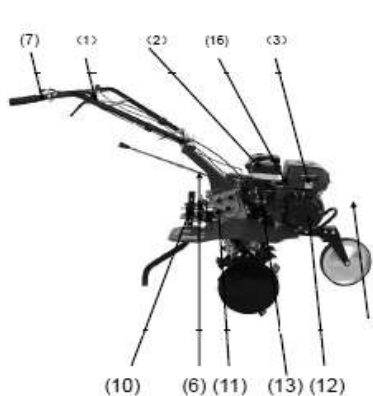

- | | |
|----------------------|----------------------------------|
| (1) Engine switch | (9) Handle height adjust |
| (2) Muffler | (10) Drag bar |
| (3) Fuel tank. | (11) Transmission oil filler cad |
| (4) Front wheel | (12) Recoil starter |
| (5) Belt cover | (13) Fuel valve |
| (6) Shift lever | (14) Choke lever |
| (7) Throttle control | (15) Air cleaner |
| (8) Clutch | (16) Spark plug |

Control

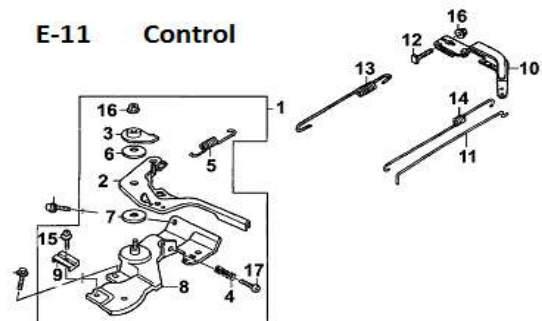

SL-No	KK-No	KK-Name	Qty
1	E11-01	Speed Adjustment Base Ass.	1
2	E11-02	N/A	1
3	E11-03	N/A	1
4	E11-04	Adjustment Spring	1
5	E11-05	Throttle spring	1
6	E11-06	N/A	1
7	E11-07	N/A	2
8	E11-08	N/A	1
9	E11-09	N/A	1
10	E11-10	Speed Adjustment arm	1
11	E11-11	Pulling Rod	1
12	E11-12	Quadrante bolt M6x21	1
13	E11-13	Return Spring	1
14	E11-14	Fine Adjustment Spring	1

SL-No	KK-No	KK-Name	Qty
10	E9-10	Starter spring	1
11	E9-11	Friction Spring 16x1	1
12	E9-12	Bolt M6x12 Flanged Hex	3

Fan Cover

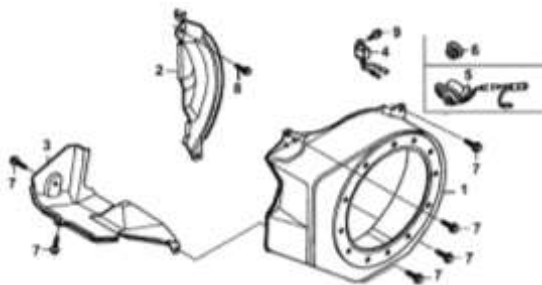

SL-No	KK-No	KK-Name	Qty
1	E10-01	Fan cover	1
2	E10-02	Side Plate	1
3	E10-03	Wind guide	1
4	E10-04	Current Amplifier	1
5	E10-05	Engine switch	1
6	E10-06	N/A	1
7	E10-07	Bolt M6x12 Flanged Hex	6
8	E10-08	Bolt M6 x 20 Flanged Hex	1

KK-IC-205P:

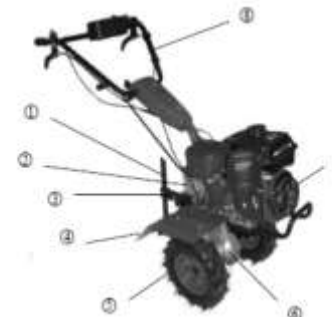

- | | |
|-------------------|-----------------|
| ①. Resistance rod | ⑤. Wheel |
| ②. Gear box | ⑥. Walking case |
| ③. Tow bar | ⑦. Engine |
| ④. Dust fender | ⑧. Handle bar |

Assembly

1. Assembling After Packing

1.1 Fix the machine, attach the wheels on both side of machine and use pin to fix wheels.
1.2 Handle assembly: Match gear plate on handle with gear plate on handle seat, and then adjust straight position of handle, and then use long bolt, spring washer, and locked grip to lock handle. Then use cable clip to hold clutch cable, reverse gear cable, and throttle cable on handle.

2. Assemble and Adjust Cable

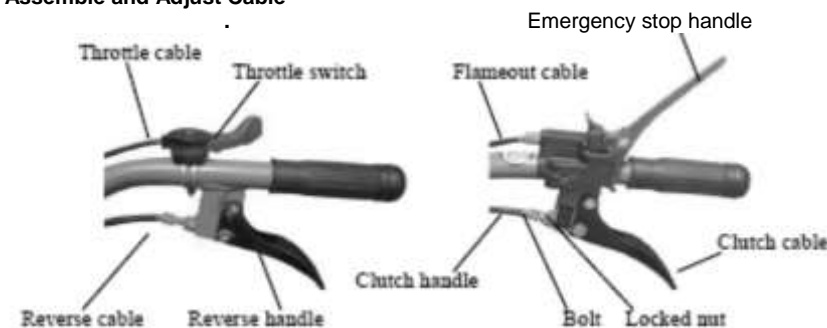

2.1 Adjustment of clutch cable

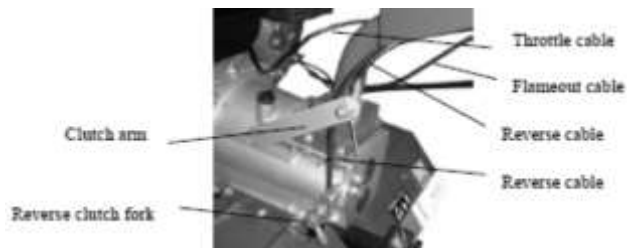

1. Loosen the locked nut.
2. Deasil turn bolt into shortest.
3. Put cable head into clutch cable seat of transmission box, and make sure that cable head is in the big hole.
4. Put steel wire into M8 hole of clutch arm seat, press clutch arm fork, and hang cable head on clutch cable seat.
5. Turn off Bolt, and hold it tightly. Loosen the clutch handle until spring in clutch can return handle, and then locked nut.

2.2 Adjustment of reverse cable.

1. Loose locked nut.
2. Deasil turn bolt into shortest.
3. Put cable head into clutch cable seat of transmission box, and make sure that cable head is in the big hole.
4. Anticlockwise turn reverse fork axle, and put cable through narrow slot, and make sure head into big hole of seat.
5. Turn off Bolt, and hold it tightly. Loose reverse handle until spring in clutch can return handle, and then locked nut.

2.3 Adjusting of throttle cable. (Drawing 4)

1. Turn throttle switch into max.
2. Put steel wire of throttle cable through wire seat and fixed seat which is on control panel.
3. Tight steel wire, locked screw on locked seat
4. Adjust fuel switch some time, until fuel rod on control panel into max.

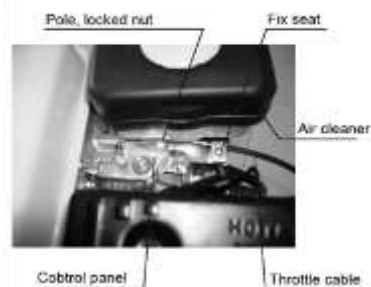

SL-No	KK-No	KK-Name	Qty
27	E8-27	N/A	1
28	E8-28	N/A	1

Recoil Starter

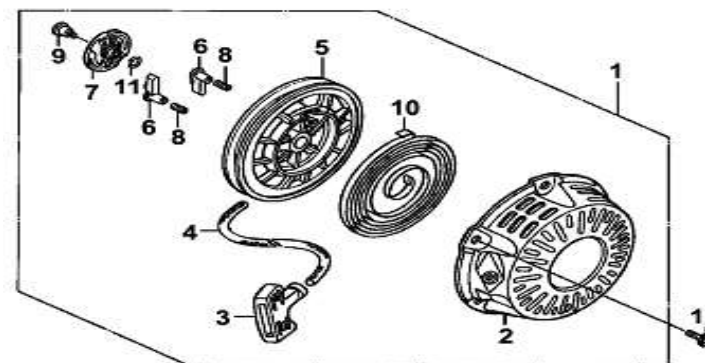

SL-No	KK-No	KK-Name	Qty
1	E9-01	Recoil Starter Assy	1
2	E9-02	Starter cover	1
3	E9-03	Pulling handle	1
4	E9-04	Rope	1
5	E9-05	Roller/Rope Reel	1
6	E9-06	Ratchet	2
7	E9-07	Ratchet guide	1
8	E9-08	Ratchet Spring	2
9	E9-09	Pivot Bolt	1

SL-No	KK-No	KK-Name	Qty
5	E8-05	Adjustment screw Idle speed	1
6	E8-06	Screw(Fuel Cup)	1
7	E8-07	Tighten bolt (Fuel cup)	1
8	E8-08	Chock Valve Assy	1
9	E8-09	Carburetor Assy	1
10	E8-10	Adjustment Screw Assy (mixture ratio)	1
11	E8-11	Main Nozzle	1
12	E8-12	O-ring 21x2(Sediment cup)	1
13	E8-13	Block, Carburetor/Insulator	1
14	E8-14	Gasket, inlet port	1
15	E8-15	Steel gasket	1
16	E8-16	Gasket carburetor	1
17	E8-17	Hand grip chock valve assy	1
18	E8-18	Handle Bar Fuel on/off	1
19	E8-19	Upper cover(Fuel on/off)	1
20	E8-20	Spring Washer-(Fuel on/off)	1
21	E8-21	Fuel Valve	1
22	E8-22	Sediment cup	1
23	E8-23	Screw M3x7	2
24	E8-24	N/A	1
25	E8-25	Main jet	1
26	E8-26	Measure hole Assy idle speed	1

Operation Check

Engine Oil:



- CAUTION**
- Running the engine with low oil level will cause serious engine damage.
 - Remove the oil filler cap and wipe the dipstick clean.
 - Insert the dipstick into the oil filler neck but do not screw it in.
 - If the level is low, fill the recommended oil to the top of the oil filler neck.
 - Use high-detergent, premium quality 4-stroke engine oil, certified to meet or exceed automobile manufacturer's requirement for API Service Classification
 - Using non-detergent oil or 2-stroke engine oil could shorten the engine's service life.
 - SAE 10W-30 is recommended for general all-temperature use. Other viscosities shown in the following chart might be used when at the average temperature in your area is within the indicated range.

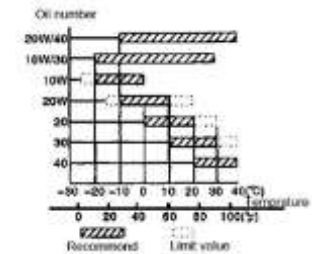
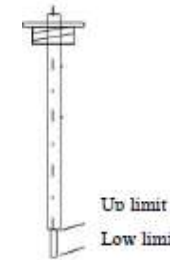

Transmission Gear Oil:

Place the Inter-cultivator on a flat surface and remove the oil filler cap. The oil should be level with the lower edge of the oil filler hole. Add high quality engine oil if the level is low. Check the air cleaner for dirt or obstruction of elements



Fuel:

Use automotive petrol (Unleaded or low leaded is preferred to minimize combustion chamber deposits.) Never use an oil/petrol mixture or dirty petrol. Avoid dirt, dust or water accumulation in the fuel tank.



CAUTION:

Do not fill over the red level line.(shown in the figure below)

**RED
LEVEL
LINE:**



WARNING

- Petrol is extremely flammable and is explosive under certain conditions.
- Refuel in a well-ventilated area after stopping the engine. Do not smoke or allow flames or spark in the area where the engine is refueled or where the petrol is stored.
- Do not overfill the fuel tank (there should be no fuel in the filler neck). After refueling, make sure the tank cap is closed properly and securely.
- Be careful not to spill fuel when refueling. Spilled fuel or fuel vapor may ignite. If any fuel is spilled, make sure the area is dry before starting the engine.
- Avoid repeated or prolonged contact with skin or breathing of vapor.

Fuel tank capacity: 3.0L or 3.6L

Petrol containing alcohol: If you decide to use a petrol containing alcohol (gasohol), be sure it's octane rating is at least as high as that recommended for Cultivators. There are two types of "gasohol": one containing ethanol and the other containing methanol! Do not use gasohol that contains more than 10% ethanol! Do not use petrol containing methanol (methyl or wood alcohol) that does not also contain inhibitors for methanol corrosion! Never use petrol containing more than 5% methanol, even if it has corrosion inhibitors.

NOTE:

- Fuel system damage or engine performance problems resulting from the use of fuels that contain alcohol are not covered under the warranty. Cultivators cannot endorse the use of fuels containing methanol since evidence of their suitability is not yet proven.
- Before buying fuel from an unfamiliar station try and find out if the fuel contains alcohol, if it does, confirm the type and percentage of alcohol used. If you notice any undesirable operating symptoms while using a petrol that contains alcohol or one that you think contains alcohol switch to a petrol that you know does not contain alcohol.

Tools & Attachments:

To install a tool or attachment to the Inter-cultivator follow the instructions furnished with the tool or attachment. Ask you dealer for advice if you encounter any problem or difficulty in installing a tool or attachment.

Start

- Start engine according to the instructions given for engine operation.
- Engine should work at idling speed (1450-1750r/min) for two or three minutes.

SL-No	KK-No	KK-Name	Qty
14	E7-14	Cam Shaft Assy	1
15	E7-15	N/A	1
16	E7-16	N/A	1
17	E7-17	Inlet valve oil seal	1

Carburetor

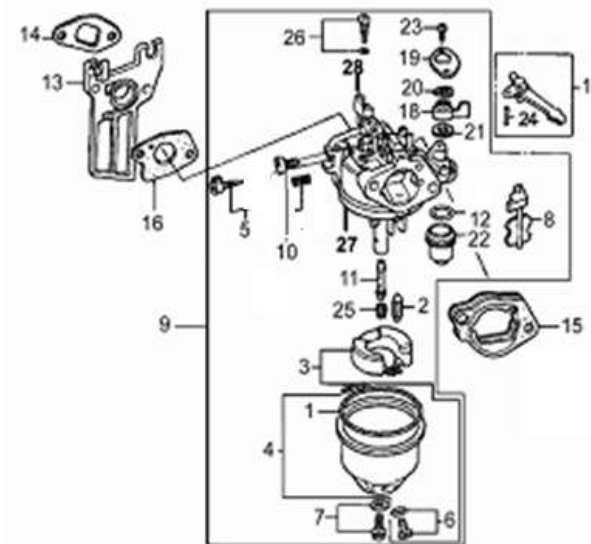

SL-No	KK-No	KK-Name	Qty
1	E8-01	Rubber seal (Fuel cup)	1
2	E8-02	Needle Valve	1
3	E8-03	Fuel Floater	1
4	E8-04	Fuel cup	1

Camshaft

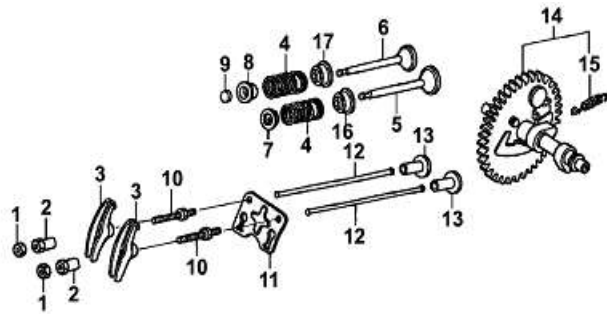

SL-No	KK-No	KK-Name	Qty
	E7-1,2,3,10	Rocker Assy	1
1	E7-01	Buy Rocker Assy	
2	E7-02	Buy Rocker Assy	
3	E7-03	Buy Rocker Assy	
4	E7-04	Valve Spring	2
5	E7-05	Intake Valve	1
6	E7-06	Exhaust Valve	1
7	E7-07	Spring seat Intake Valve	1
8	E7-08	Spring Seat Exhaust Valve	1
9	E7-09	Cap Exhaust Valve	1
10	E7-10	Buy Rocker Assy	2
11	E7-11	Pusher guide	1
12	E7-12	Pusher	2
13	E7-13	Tappet	2

- Check if engine is working properly, if not, stop to check.

1. Operation

! NOTE: Tiller should break-in before use.

1.1 Using of flameout switch.



Start place

Stop place

- 1.1.1 Start: Turn flameout switch to the place as shown above and use lock clip to block switch. And then start the engine
- 1.1.2 Work: While working, hold flameout switch. Turn lock clip back. And hold on clutch rod to change gear. Then hold on flameout switch, and release clutch rod and then start tilling.
- 1.1.3 In emergency situation, release flameout switch to stop the engine.

! WARNING: While tilling, don't turn lock clip.

1.2 Slow gear

- 1.2.1 Hold on the clutch rod with left hand and meanwhile press down flameout switch to disengage the clutch.
- 1.2.2 Pull back the shift gear rod with right hand and then turn to slow gear. After shifting the gear, use right hand to hold the handle grip.

! NOTE: Don't hold reverse handle during the above situation.

- 1.2.3 Slowly release clutch rod, then clutch will engage and tiller can work at slow speed.
- 1.2.4 Turn accelerator to bigger, then tiller can work on slow gear at 5km/h.

1.3 Fast gear

- 1.3.1 Hold on clutch rod with left hand and meanwhile press down flameout switch to disengage clutch.
- 1.3.2 Pull back the shift gear rod with right hand and then turn to fast gear. After shift gear, use right hand to hold handle grip.

! NOTE: Don't hold reverse handle during the above situation.

- 1.3.3 Slowly release clutch rod, then clutch will engage, and tiller can work at slow speed.
- 1.3.4 Increase the accelerator, then tiller can work on fast gear at 10km/h.

1.4 Reverse gear

- 1.4.1 Hold on clutch rod with left hand and meanwhile press down flameout switch to disengage clutch.
- 1.4.2 Pull back the shift gear rod with right hand and then turn to neutral gear. And then use right hand to hold on reverse handle.
- 1.4.3 Then slowly release clutch rod so that the tiller can go in reverse direction

! NOTE: Don't release reverse handle. And before turning to reverse gear, must turn accelerator to smaller (but engine should not stop, the speed will be about 2000r/min) which will be safer.

1.4.4 When there is no need of reverse gear, hold on the clutch and right handle, release the reverse handle.

1.5 When tiller is moving, don't shift the gear. First reduce the accelerator and then release clutch, until tiller stop walking, the shift gear.

1.6 Turning. Turning handle to left or right can turn tiller.

! NOTE: While turning, don't hold wrong handle or rod, else, gears will be damaged.

1.7 Stop

1.7.1 Hold clutch rod, and meanwhile hold flameout switch to disengage clutch.

1.7.2 Turn shift gear rod to neutral, loosen clutch rod, then tiller will stop working.

1.7.3 If engine need to be stopped

Connecting the attachments

Tilling:

When need tilling, disassemble walking wheel, and then put blades onto both side of axle. And use pin and clip to fix. After blades are assembled, must assemble dust fender. Dust fender can protect. Tilling depth can be adjusted by deep resistance rod.

Ditching:

When need to do ditching work, take off deep resistance rod, adjust ditching blades height, and then start ditching work.

Ditching width: 40cm

Ditching depth: 11-25cm

Usage

! NOTE:

- If you hear any strange noise while working on tiller, stop the engine to check.
- When tiller is cool, don't add heavy load. Especially if working with new machine and machine which is being used after a long time/ repair.
- Check to see if there is oil in transmission box, if no oil, please add.
- Do not pour water on tiller for cooling it.
- Don't allow the tiller with blades move on hard road.
- After using, clean the tiller which will prolong the life of the tiller. Clean the air cleaner element periodically and change it if necessary.

Crankshaft Piston

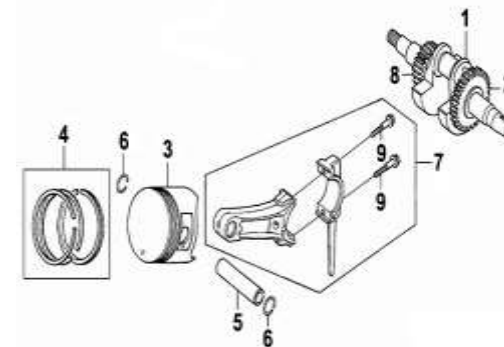

SL-No	KK-No	KK-Name	Qty
1	E6-01	Crankshaft Assy	1
2	E6-02	Governor Gear	1
3	E6-03	Piston	1
4	E6-04	Piston Ring Assy	1
5	E6-05	Piston Pin	1
6	E6-06	Clip Piston Pin	2
7	E6-07	Connecting rod Assy	1
8	E6-08	Timing Gear	1
9	E6-09	Bolt connecting rod M7x35	2

Crankcase Cover

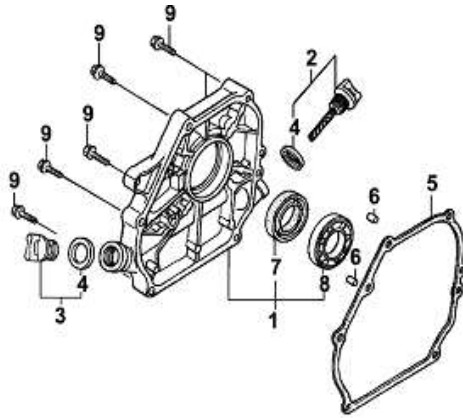

SL-No	KK-No	KK-Name	Qty
1	E5-01	Crankcase cover	1
2	E5-02	Oil Gauge	1
3	E5-03	Oil Plug assembly	1
4	E5-04	seal-oil gauge	2
5	E5-05	Gasket crankcase	1
6	E5-06	Set pin 8X14	2
7	E5-07	Oil Seal 25x41.25x6	1
8	E5-08	Ball Bearing 6205	1
9	E5-09	Bolt M8 x 30	6

Starting the Engine



Be sure the clutch is disengaged and the shift lever is in the neutral position to prevent sudden uncontrolled movement when the engine starts. The clutch is engaged by pulling in the clutch lever and disengaged by releasing the lever.

- Turn the fuel valve to ON. Checkup tightness of drain knob.
 - Fuel Valve
 - On
 - Drain Knob

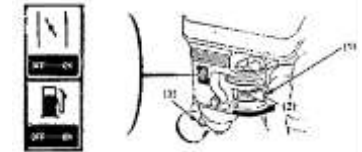

- Close the choke lever.

NOTE: Do not use the choke if the engine is warm or the air temperature is high.

 - Choke Lever
 - Close

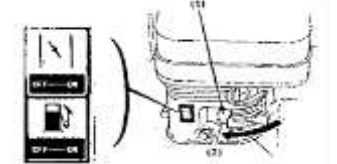

- Turn the engine switch to ON
 - On
 - Engine Switch

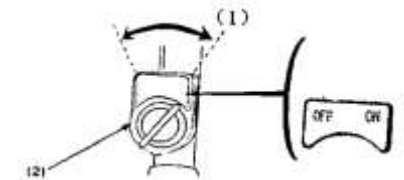

- Move the throttle lever slightly to the right.
 - Throttle Lever

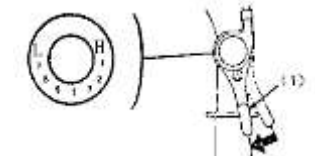

- Pull the starter grip lightly until resistance is felt then pull briskly.

CAUTION: Do not allow the starter grip to snap back against the engine. Return it gently to prevent damage to the starter.

 - Starter Grip



6. As the engine warms up. Gradually open the choke.
 - (1) Choke Lever
 - (2) Open

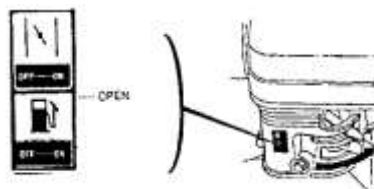

High altitude operation:

- At high altitude the standard carburetor air-fuel mixture will be excessively rich. Performance and fuel consumption will increase.
- High altitude performance can be improved by installing a smaller diameter main fuel jet in the carburetor and readjusting the pilot screw. If you always operate the cultivator at altitudes higher than 1.830m (6.000feet) above sea level ask your authorized Cultivators dealer to perform these carburetor modifications.
- Even with suitable carburetor jetting, engine horsepower will decrease approximately 3-5% for each 305m (1.000foot) increase in altitude.
- The effect of altitude on the horsepower will be greater than this if no carburetor modification is made.



CAUTION

Operation of the Inter-cultivator at an altitude lower than the carburetor is jetted for may result in reduced performance, overheating and serious engine damage caused by an excessively lean air / fuel mixture.

Inter-Cultivator Operation

A. Handlebar height adjustment:

CAUTION: Before adjusting the handlebar place the cultivator on firm level ground to prevent the handle from collapsing accidentally.

- To adjust the handlebar height, loosen the adjuster select the appropriate holes and tighten the adjuster.



B. Tilling Depth Adjustment:

- Install the hitch attachment in the hitch box with a hitch pin.
- The tilling depth adjustment can be made as follows:
Remove the pin and lock pin loosen the bolt securing the drag bar and sliding the drag bar up or down as necessary.

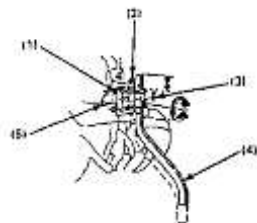

SL-No	KK-No	KK-Name	Qty
1	E4-01	Crankcase Body	1
2	E4-02	O-ring 14mm	1
3	E4-03	Drain bolt	2
4	E4-04	N/A	1
5	E4-05	Sway bar	1
6	E4-06	N/A	1
7	E4-07	Split Clip	1
8	E4-08	Washer Drain bolt	2
9	E4-09	N/A	1
10	E4-10	Centrifugal gear Parts	1
11	E4-11	N/A	1
12	E4-12	Plain washer 6mm	2
13	E4-13	N/A	2
14	E4-14	N/A	1
15	E4-15	N/A	2
16	E4-16	Oil sensor Assy	1
17	E4-17	Oil seal crankcase(25*41.25*6)	1
18	E4-18	Ball Bearing 6205	1
19	E4-19	Bolt M6 x 14	2
20	E4-20	Nut M10	1

SL-No	KK-No	KK-Name	Qty
10	E3-10	Stud Intake Port M6 x 113	2
11	E3-11	Stud Exhaust Port M8 x 32	2
12	E3-12	Set pin 10x14	2
13	E3-13	Bolt M6x12	4
14	E3-14	Bolt M8 x 60,	4

Crankcase Assembly

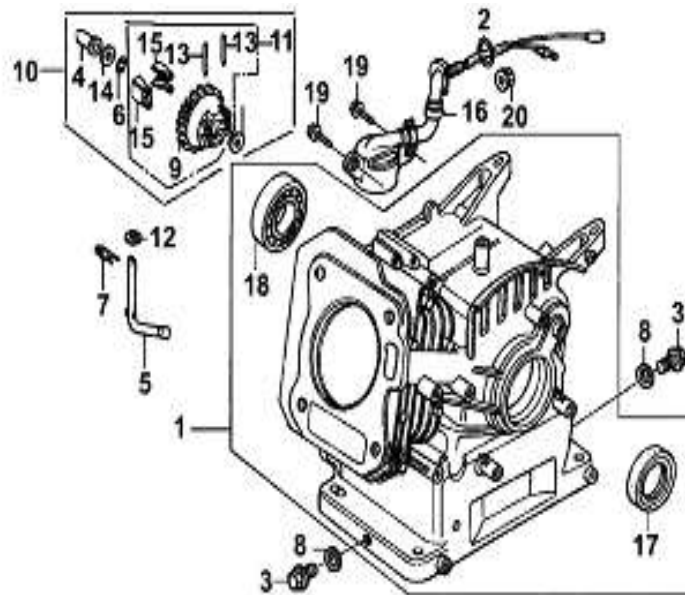

- (1) Hitch Box
- (2) Hitch Pin
- (3) Lock Pin
- (4) Drag Bar
- (5) Pin

C. Clutch Operation:

CAUTION: Reduce engine RPM before operating main clutch.

- The clutch engages and disengages the power from the engine to the transmission.
- When the clutch lever is squeezed the clutch is engaged and power is transmitted. Squeeze the lever. The tool will be rotated.
- When the lever is released the clutch is disengaged and power is not transmitted. Release the clutch lever. The tool will be stopped.

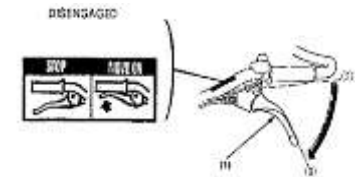

- (1) Clutch Lever
- (2) Engaged
- (3) Disengaged

D. Gear selection:

The transmission can be shifted into the 2nd forward gear. The shift lever should be operated in accordance with the attached gear shifting plate.

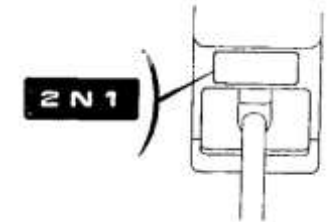

Gear shifting:

- Return the throttle lever to the extreme right.
- Release the clutch lever to disengage the clutch
- Move the shift lever to the desired gear position
- Squeeze the clutch lever to engage the clutch

NOTE: If the shift lever will not engage the desired gear squeeze the clutch lever and move the cultivators slightly to reposition the gears.

E. Choose the gear:

The Inter-cultivator has three gears to choose from:

Gear Conversion:

- Pulling the throttle switch to the right
- Unloosen the clutch handle and let the clutch separate.
- Moving the gear shifting arm to your required gear

Gear Shifting:
Reverse (-1)
Forward (1)
Neutral (0)
Forward (2)



- Gripping the clutch handle, the engine will work on the converted gear.

F. Use of a Hitch Box:

Install the hitch attachment in the hitch box with a hitch pin.

- Hitch Box
- Hitch Pin

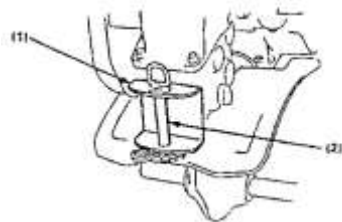

G. Front Wheel:

Move the Inter-cultivator on road by the front wheel; lift the handlebars up the ground the front wheel.

When the cultivator is used in the field, move the wheel up by replacing the lock pin.

- When used in the field
- Lock Pin
- When moved on road

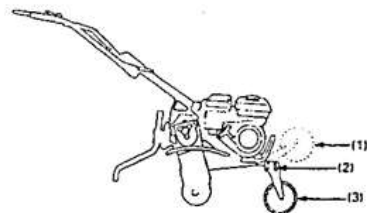

H. Handling Tips:

Adjust the handlebar height to a comfortable position (waist height for normal tilling). Should the machine jerk forward while tilling. Press down the handlebars. If the machine does not move forward, move the handlebars from side to side.

Turn:

The proper method of negotiating a turn during a tilling operation is to lower the handlebars to bring the gravity center towards the rear and then make the turn, this will permit a turn to be made with relative ease.

I. Normal Operating Angle:

Lower the handle slightly so that the front of the machine is raised about 6-8°

To get the maximum advantage from the cultivator, try to hold the machine at an angle shown while you are tilling the ground.

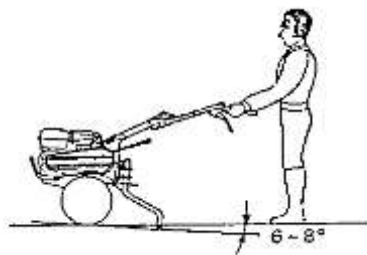

CAUTION:

- Do not use the Inter-cultivator with a rotor whose diameter is in excess of 300mm.
- Operating the cultivator on grades could cause the cultivator to trip over.
- Allowing any one to operate this cultivators without proper instruction may result in injury.

Engine Parts Diagram & List- KK – PE4 - 203

Cylinder Head

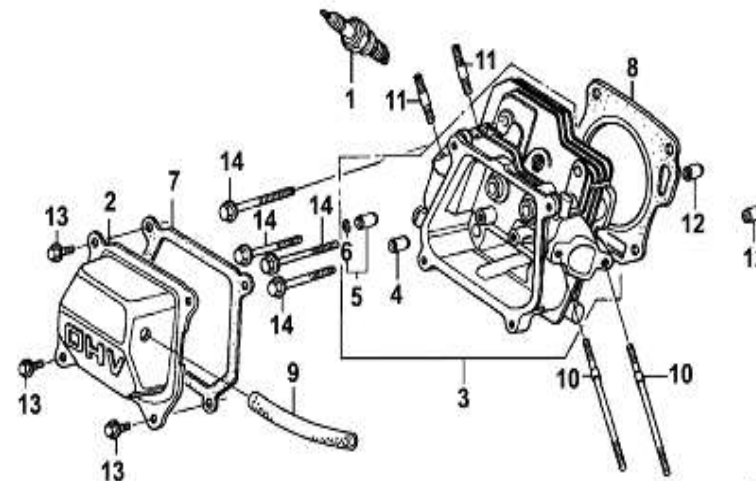

SL-No	KK-No	KK-Name	Qty
1	E3-01	Spark plug	1
2	E3-02	Cylinder head cover	1
3	E3-03	Cylinder head Assy	1
4	E3-04	In. valve guide	1
5	E3-05	Ex. valve guide	1
6	E3-06	Valve guide clip	1
7	E3-07	Gasket Cylinder head cover	1
8	E3-08	Gasket Cylinder head	1
9	E3-09	Air duck/Pipe	1

2 months to 1 year	<ul style="list-style-type: none"> • Fill with fresh gasoline and add gasoline conditioner • Drain the carburetor float bowl • Drain the fuel sediment cup
--------------------	---------------------------------------------------------------------------------------------------------------------------------------------------------------------------------------------

Storage

If the engine is not used for a long time, do the necessary maintenance before its storage.

- Firstly, take off the fuel tank, drain out all fuel, and clean the dirt and water inside the tank. Open the fuel cock, unscrew the drain plug at the bottom of carburetor, drain out fuel in carburetor thoroughly, and then tighten the drain plug.
- Secondly, unscrew the drain plug at the bottom of the crankcase and drain out the lubricant oil in the crankcase thoroughly, then tighten the drain plug.
- Finally, clean the surface of the engine with clean cloth, remove the dirt and dust etc. Then store the engine in a well-ventilated, dirt-free place.

Transportation

- Contact with the hot engine or exhaust system can cause serious burns or fires. Allow the engine to cool down before transporting or storing the engine.
- During transport of the engine, turn the engine switch and the fuel valve to OFF. Keep the engine cool.

Troubleshooting

1. The Engine Can't Startup

- Have the engine checked if it is hard to or cannot be started.
- Firstly, check the fuel level of the fuel tank. Turn fuel valve to (2), Fuel should flow from the drain when the fuel valve is turned ON. Tighten the drain plug. (Refer to starting of the engine)

2. Spark Plug

Check the spark plug. Remove the spark plug cap and clean any dirt around it. If the engine still cannot be started after repeating several times, please see the authorized dealer. Users are not allowed to dismantle or reassemble the unit by themselves.

3. Not Enough Power

- Check the air-cleaners. Please refer the maintenance inspection book to clear the air-cleaner.
- Check the fuel. Please strain out the gasoline in fuel tank and in carburetor, and fill in new gasoline.
- For any other trouble, please contact our dealer.

- Wear sturdy full coverage footgear. Operating this cultivator with bare feet or with open toe shoes or sandals increase your risk of injury.
- Do not use the cultivator in the night.
- Be sure to use two people to transport the cultivator from one place to another without using a carrier.
- When the rotor is clogged with mud, pebble etc. immediately stop the engine and clean the rotor in a safe place. Be sure to wear heavy gloves when cleaning the rotor.

To prevent damage, check the cultivator for any signs of damage or other faults each time the cultivator is used after it has been operated last.

During an Emergency:

Turn the engine switch to "OFF"

- (1) Off
- (2) Engine Switch

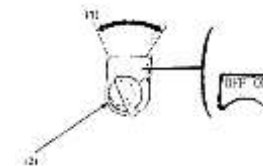

During Normal Use:

Release the clutch lever to DISENGAGED position and shift lever is in neutral position.

- (1) Clutch Lever
- (2) Disengaged

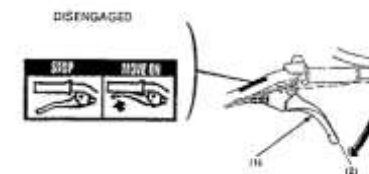

Stopping the Engine

A. Move the throttle lever fully to the right.

- (1) Throttle Lever

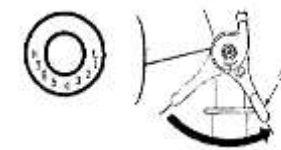

B. Turn the engine switch to OFF

- (1) Off
- (2) Engine Switch

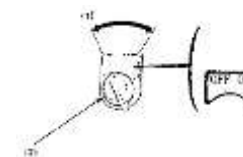

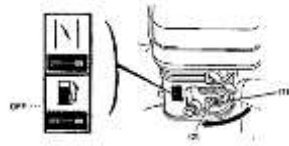

- C. Turn the fuel valve to OFF
- (1) Fuel Valve
 - (2) Off



Maintenance

The purpose of the maintenance schedule is to keep the Inter-cultivator in the best operating condition. Inspect or service as scheduled in the table below.

 WARNING	Shut off the engine before performing any maintenance. If the engine is running, make sure the area is well ventilated. The exhaust contains poisonous carbon monoxide gas.
 CAUTION	Always use genuine KK-IC-200P parts or their equivalent. The use of replacement parts which are not of equivalent quality may damage the engine.

Maintenance Schedule:

Component	Action to be taken	Period				
		Daily	First Month or 20 Hrs.	Every 3 months or 50Hrs.	Every 6 months or 100 Hrs.	Every year or 300 Hrs.
Engine oil	Check level	✓				
	Change		✓		✓	
Air Cleaner Element	Check	✓				
	Clean			✓ (1)		
Fuel Strainer Cup	Clean				✓	
Spark Plug	Clean-readjust				✓	
Transmission Gear Oil	Check level	✓				
Tappet Clearance	Check – Readjust					✓ (2)
Fuel Tank and Strainer	Clean					✓ (2)
Clutch Cable	Adjust		✓		✓	
Throttle Cable	Adjust					✓
Belt Tension	Adjust		✓		✓	
Fuel Line	Check	Every 2 Years (2) (Replace if necessary)				

- Remove the drain plug and sealing washer, remove the oil filler cap, and drain the oil.
- Reinstall the drain plug and sealing washer. Tighten the plug securely.
- Refill with the recommended oil and check the oil level.



(1) Dismantle Spark Plug

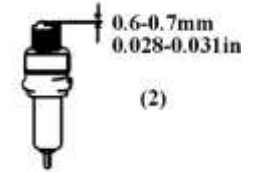

(2) Adjust Clearance

4. Clean the fuel tank and filter when working time reaches 100hrs: Remove the fuel cover, drop out filter, and wash it with brush slightly. Remove fuel tank, clean the fouling and water inside fuel tank. Reinstall fuel tank, place filter from fill-in hole, filling the clean fuel to red line level.

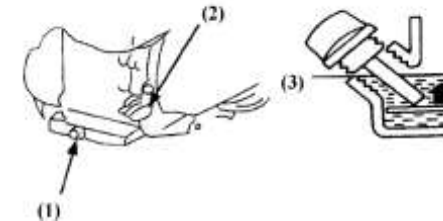

- 1) Drain plug
- 2) Engine switch
- 3) Lower level

Check aging of fuel pipe every 2 years. If ageing, hardening and cracking is detected, have it replaced. Tighten the joints, and check leakage.

Before storing the unit for an extended period:

1. Make sure the storage area is free of excessive humidity and dust.
2. Service according to the table below.

Storage Time	Recommended Service Procedure To Prevent Hard Starting
Less than 1 month	No preparation required
1 to 2 months	Fill with fresh gasoline and add gasoline conditioner

! DANGER:

- Gasoline is extremely flammable and explosive under certain conditions.
- Refuel in well-ventilated places with the engine stopped. Do not smoke or allow flames or sparks near the places where the engine is refueled or gasoline is stored.
- Do not add fuel over the shoulder of strainer. After fueling, tighten the tank cover.
- Fuel vapors are extremely flammable and may ignite after the engine has started. Make sure that any fuel spillage has been wiped off before starting the engine.
- Avoid skin coming in contact with gasoline for a long time, avoid breathing in gasoline vapors. Keep children away from them.

NOTE:

Fuel can damage paint and plastics. Be careful when refueling. Damage caused by spilling fuel is not covered under warranty.

Maintenance

Do periodic maintenance to keep the engine in good condition. Always follow the inspection and maintenance recommendation and schedules given in this manual.

! WARNING:

Stop the engine before doing any maintenance work. If the engine must be operated, provide adequate ventilation. Breathing in exhaust can cause loss of consciousness and even lead to death.

Everyday Maintenance:

1. **Air cleaner:** A dirty air cleaner will restrict air flow into the carburetor. To prevent carburetor malfunction, service the air cleaner regularly. Service more frequently when operating the generator in extremely dusty areas.
 - Check air cleaner core, get rid of fouling, and keep the core clean.
 - Check bolts, fasten the loose ones.
 - Check whether lubricant oil level is within the limits.
2. Clean the core after 25hrs of engine run
3. Clean carbon fouling of the spark plug after working up to 50hrs. Check the clearance, and adjust the gap to 0.6-0.7mm (see figure 4-1). Check radiator, and clean fouling among radiators.
 - Drain the oil while the engine is warm to assure rapid and complete draining.

NOTE

1. Service more frequently when used in dusty areas.
2. These items should be serviced by an authorized KK-IC-200P dealer, unless the owner has the proper tools and is mechanically proficient. See the KK-IC-200P Shop Manual.
3. Period: Perform regular service at every indicated month or operating hour interval, whichever occurs first.

A. Changing oil:

Drain the oil while the engine is still warm to assure rapid and complete draining

- Remove the oil filler cap, and drain the oil
- Refill with the recommended oil and check the level

Oil capacity: 0.6 L

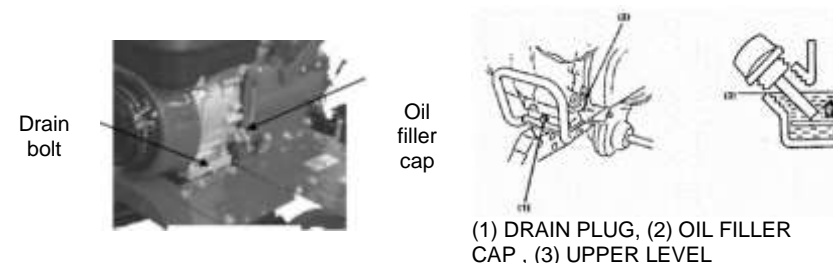

Wash your hands with soap and water after handling used oil.

NOTE:

Please dispose the used motor oil in a manner that is compatible with the environment. We suggest you take it in a sealed container to your local service for reclamation. Do not throw it in the trash or pour it on the ground.

! WARNING: Petrol is highly flammable and explosive under certain conditions. Do not smoke or allow flames of sparks in the area.

B. Fuel strainer cap cleaning:

Turn the fuel valve to the OFF position and remove the fuel strainer cup and the O-ring. Wash the removed parts in solvent, dry them thoroughly and reinstall securely. Turn the fuel valve ON and check and leaks.

- (1) O-RING
- (2) FUEL STRAINER CUP

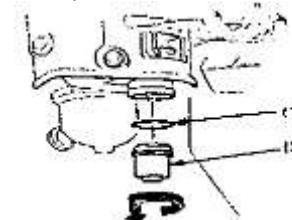

C. Air cleaner service:

A dirty air cleaner will restrict air flow to the carburetor. To prevent malfunction, service the air cleaner regularly. Service more frequently when operating the engine in extremely dusty areas, as follows:

- Remove the wing nut and the air cleaner cover. Remove the elements and separate them. Carefully check both elements for holes or tears and replace if damaged.
- **Foam element:** Clean with warm soapy water, rinse and allow to dry thoroughly. Or clean with high flash-point solvent and allow it to dry.
- **Paper element:** Tap the element slightly several times on a hard surface to remove any excess dirt, or blow compressed air through the filter from the inside out. Never try to brush the dirt off; brushing will force dirt into the fibers.

⚠ WARNING: Never use petrol or low flash point solvents for cleaning the air cleaner element. A fire or explosion could result in.

CAUTION: Never run the engine without the air cleaner.

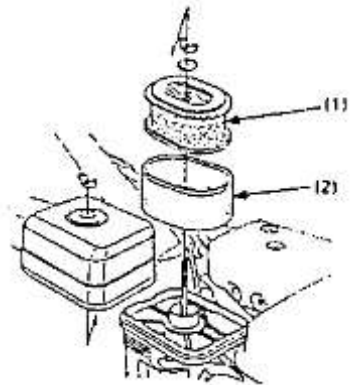

(1) PAPER ELEMENT
(2) FOAM ELEMENT

D. Spark plug service:

To ensure proper engine operation the spark plug must be properly gapped and free of deposits.

- Remove the spark plug cap.
- **WARNING:** If the engine has been running initially, the muffler will be very hot. Be careful not to touch the muffler.
- Visually inspect the spark plug. Discard it if the insulator is cracked or chipped.
- Measure the plug gap with a feeler gauge. The gap should be 0.7-0.8mm (0.028-0.031in). Correct as necessary by bending the side electrode.

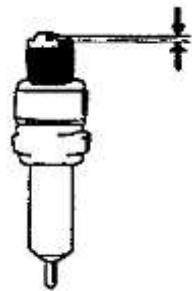

- Once the engine got started, let it run for 1-3 minutes at idle speed, check whether it is balanced, cracked, then pull the throttle to open position, adjust choke rod to OPEN.



(1) Auto-Throttle (2) Off Position (3) Starter Knob

Electrical Starting:

Turn the engine switch to START position and hold a while until the engine started



ENGINE SWITCH

NOTE: Restrict the starting time within 5 seconds to avoid engine damage. If engine cannot be started, release starter knob, retry after 10 seconds.

Stopping The Engine

Adjust throttle to proper position. Reduce engine speed, close the choke. Turn engine switch to OFF position.

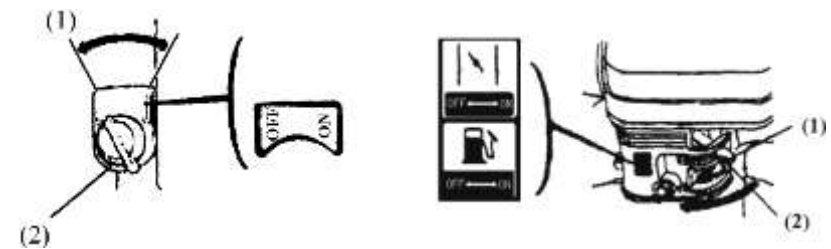

(1) Throttle knob (2) Throttle is at OFF

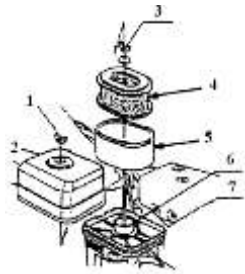

- 1) Butterfly nut
- 2) Air cleaner cover
- 3) Butterfly nut
- 4) Paper element
- 5) Foam element
- 6) Seal washer
- 7) Silencer plate

! WARNING:

Do not run the engine without air cleaner.

! DANGER

Using gasoline or flammable solvent to clean the filter element can cause a fire or explosion.

! CAUTION:

Do not run the engine without air cleaner core, otherwise dust and/or other foreign matters may get into the engine through carburetor, and results in rapid engine worn-out.

Starting The Engine

- Turn the fuel valve to ON position, unscrew the drain plug on carburetor bottom, and fasten the drain plug until oil spills out.
- Pull the choke rod to the CLOSE position. Adjust throttle to proper position. Pull the starter grip lightly until resistance is felt, then pull it rapidly

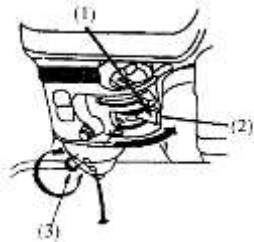

(1) Fuel Valve

(2) Start Level

(3) Drain Plug

NOTE:

- Do not allow the starter grip to snap back against the engine. Return it gently to prevent damage to the starter.

- Attach the plug washer. Thread the plug in by hand to prevent cross-threading.
- When mounting a new spark plug, you should screw 1/2 more thread with the wrench after the washer is compressed. If you are mounting an old one, you should only screw 1/8 – 1/4 more thread.

CAUTION: The spark plug must be securely tightened. An improperly tightened plug can become very hot and possibly damage the engine. Never use a spark plug with an improper heat range.

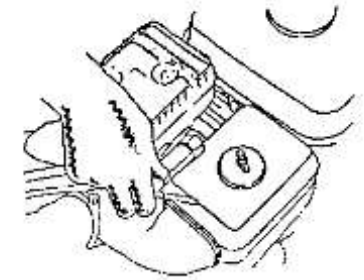

E. Clutch cable adjustment

Measure the free play at the lever tip
Free play: 3-8mm (0.1-0.3in)
If the free play is incorrect, loosen the lock nut and turn the adjusting bolt in or out as required.

- (1) LOCK NUT
- (2) ADJUSTING BOLT

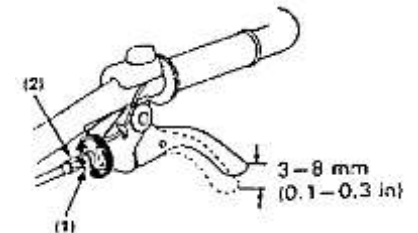

After adjustment tighten the lock nut securely. Then start the engine and check for proper clutch lever operation.

F. Throttle cable adjustment

Measure the free play at the lever tip
Free play: 5-10 mm (0.2-0.4in)
If the free play is incorrect, loosen the lock nut and turn the adjusting nut in or out as required.

- (1) THROTTLE LEVER
- (2) ADJUSTING NUT
- (3) LOCK NUT

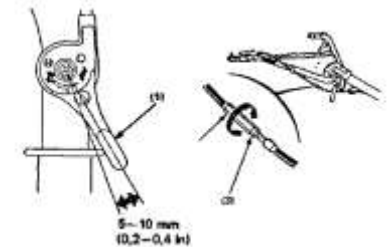

G. Belt tension adjustment:

Adjust the clutch lever free play. The standard belt tension is 60-65mm (2.4-2.6 in) at the tension roller with the clutch engaged (clutch lever is squeezed).

To adjust, loosen the four engine mounting bolts and the engine stay tightening bolt and move the engine forward or reverse to get proper tension of the belt.

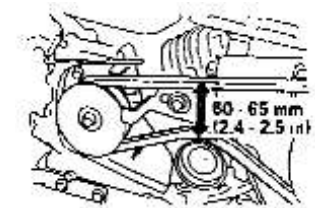

NOTE: After adjusting the tension make sure that the outside face of the drive pulley is flush with the outside face of the driven pulley by using a straight gauge.

- (1) ENGINE MOUNTING BOLTS
- (2) ENGINE STAY TIGHTENING BOLT

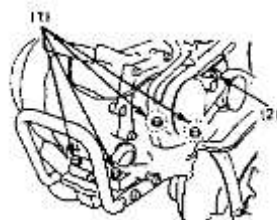

Loosen the attaching bolts of the belt stopper. Adjust the clearance between the belt stopper and the belt as illustrated with the clutch lever squeezed.

- (1) BELT STOPPERS

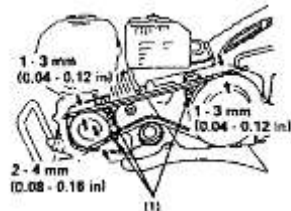

Transportation and Storage

When transporting the Inter-cultivator, turn the fuel valve OFF and keep the Inter-cultivator on a level surface to prevent fuel spillage. Fuel vapor or spilled fuel may be ignited.



WARNING

Before storing the unit for an extended period:

1. Be sure the storage area is free of excessive humidity and dust.
2. Drain the fuel

Petrol is highly flammable and explosive under certain conditions. Do not smoke or allow flames or sparks in the storage area.

- With the fuel valve turned OFF, remove and empty the fuel strainer cap.
- Turn the fuel valve ON and drain the petrol in the fuel tank into a suitable container.
- Replace the fuel strainer cap and tighten securely.
- Drain the carburetor by loosening the drain knob Drain the petrol into a suitable container.



1. O-Ring
2. Fuel Strainer Cup
3. Drain Knob

3. Pull the starter grip until resistance is felt. Continue pulling until the notch on the starter puller aligns with the hole on the recoil starter. At this point, the intake and exhaust valves are closed and this will help to protect the engine from internal corrosion.

Fuel level

- Check the fuel gauge, and refill the tank if the fuel level is low. Do not fill above the shoulder of the fuel strainer. The fuel 90# gasoline is recommended.
- Unleaded gasoline produces less engine and spark plug fouling and extends exhaust system life.
- Never use stale or contaminated gasoline or oil/gasoline mixture. Avoid dirt, rubbish and water from getting into the fuel tank.
- If spark knock or pinging occurs at a steady engine speed under normal load, change brands of gasoline. If spark knock or pinging persists, see an authorized dealer.

! WARNING:

- Running the engine with persistent spark knock or pinging can cause engine damage.
- If persistent spark knocks or pinging is caused by improper usage of the unit, the Distributor's Limited Warranty does not cover parts damaged by that.



(1) Fuel tank

(2) Fill in hole

(3) Red line level

Air cleaner

The air cleaner is a dry type including paper element and foam element.

- Remove the clip and dismantle the air cleaner housing or remove the wing nuts and air cleaner cover.
- Wash the element in solution of household detergent and warm water, then rinse thoroughly, or wash in nonflammable or high flash point solvent. Allow the element to dry thoroughly.

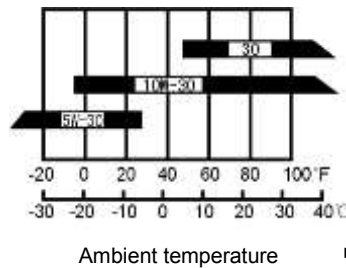

- Before checking engine lubricant oil, place the engine on level surface
- Turn out the oil filler cap and clean the dipstick with a clean cloth.
- Insert the dipstick back into the oil filler hole without turning it in.
- If oil level is below the lower mark of the dipstick, fill oil to the upper level of the dipstick.
- Reinstall the oil filler cap properly.

Upper level

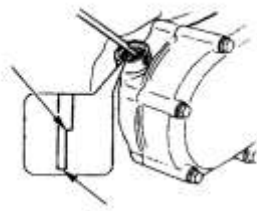

Lower level

Dipstick

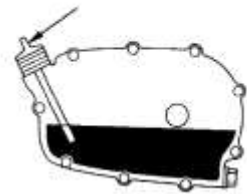

Engine oil alert system (optional function):

The oil alert system is designed to prevent engine damage caused by insufficient oil in the crankcase. When the oil level in the crankcase falls below the safe limit, the oil alert system will automatically stop the engine even if the engine switch remains at the ON position. If the engine stops and cannot be restarted, check the engine oil level before troubleshooting in other areas.

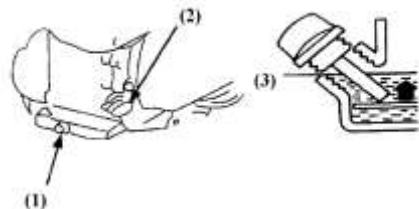

(1) Drain plug

(2) Engine switch

(3) Lower level

- (1) Align the notch on the starter pulley with the hole at the top of recoil starter.

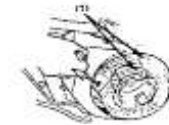

4. Change engine oil.
5. Cover cultivator with plastic sheet.
Do not place the Inter-cultivator with the handlebars on the ground. It will cause the oil entering the cylinder or the fuel spillage

Engine long time storage

- Check oil level before each use or after every 8 hours of operation.
- Change oil after first 5-8 hours of operation. Refill with new oil of recommended grade.
- Check spark plug yearly or every 100 hours of operation.
- Service air cleaner periodically.
- Keep all the engine parts clean
- Check engine and equipment often for loose nuts and bolts and keep them tightened.
- Check or Fill Engine Crank case
- Add oil according to engine manual. Do not overfill.
- Use a clean, high quality detergent oil. Do not mix oil with gasoline oil level must be full. Check the oil level by removing oil fill plug. Oil level should be up to the bottom of the fill plug opening
- Always check oil level before starting engine.

Tiller long time storage

Follow the steps below to prepare your tiller for storage

1. Protect wheels mid axles from ram:
 - Loosen locking bolt inside wheel. Slide wheel toward machine,
 - Coat the axles lightly with axle grease
 - Move wheel back into position and lock jam nut.
 - Back off Locked bolt 1/16 turn and lock jam nut.
2. Drain fuel system completely following engine manufacturer's instructions or add fuel stabilizer to prevent fuel from gumming up during extended storage period.
3. While engine is still warm, drain the oil from the engine. Refill with fresh oil the recommended grade.
4. Clean external surfaces and engine.
5. Remove spark plug, pour one ounce of SAE 30 oil into spark plug hole and pull starter cord slowly to distribute oil evenly head area
6. Take off spark plug, and store it.
7. Transport unit to a suitable storage location. If you have chosen to use a fuel stabilizer and have not drained the fuel system, follow all safety instructions and storage precautions in this manual to prevent the possibility of fire from the ignition of gasoline fumes. Take care, gasoline fumes can travel to distant sources of ignition and ignite, causing risk of explosion and fire.
8. Store the unit in an area away from human activity.

- If there is any possibility of unauthorized use or tampering, remove the spark plug and store it in a safe place before storing the rototiller unit away. Be sure to plug the spark plug hole to prevent foreign material from entering.

Technical Specifications

KK-IC-200P:

CULTIVATOR	Dimension (L x W x H) (mm)	1380x650x970
	N.W./G.W(kg)	70/73
	Transmission System	Belt + Chain
	Tilling Scope (mm)	500 - 1000
	Working Dia. (mm)	300/350
ENGINE	Engine Model	KK-PE4-203
	Type	OHV, Single-cylinder, 4-stroke , forced air cooling
	Displacement	196 cc
	Bore x stroke	68x54mm
	Compression Ratio	8.5 : 1
	Max. Output	4.5/3600 (kW/rpm)
	Rated Output	3/3600 (kW/rpm)
	Max. Torque (nm)	11N.m/2500rpm
	Ignition system	Transistor Magneto
	Starting System	Manual Start
	Oil capacity	0.6 L
	Fuel tank capacity	3.6 L
	Oil consumption	395g/kWh
	N.W./G.W	15 / 17kg
Air Cleaner	Oil Bath Filter	

KK-IC-100P/105P:

Engine	KK-PE4-101
Displacement	98.5cc
Rated power	1.4kW/ 3100RPM
Fuel Tank	1.6 liters
Oil Tank	0.35 liers
Net weight	34 kg
Tilling width	420 mm

away from the engine to avoid fire.

- Keep children and pets away from the operation area.
- Make sure that the person who operates the engine receives proper instruction.
- Keep the flammable substances (gasoline, matches) away from the operating engine.
- As gasoline is extremely flammable and explosive under certain conditions, please refuel in a well-ventilated area with the engine stopped.
- Do not fill above the shoulder of the fuel strainer.
- Make sure the fuel cover is tightened.
- Make sure that any spilled fuel has been wiped off before starting the engine.
- Do not smoke or allow flames or sparks where the engine is refueled or where gasoline is stored.
- Exhaust contains poisonous carbon monoxide, a colorless and odorless gas. Breathing exhaust can cause loss of consciousness and may lead to death. Do not operate the engine without good ventilation or in enclosed room.
- If you run the engine in an area that is confined, or even partially enclosed, the air you breathe could contain a dangerous amount of exhaust gas. Provide adequate ventilation so as to keep exhaust gas from accumulation.
- Place the engine on flat (level) surface, tilting angle of the engine should not be more than 20°, otherwise it will lead to fuel spilling out.
- Do not cover the engine so as to avoid fire occurrence.
- The muffler becomes very hot during and immediately after operation. Be careful not to touch the muffler while it is hot. Let the engine cool down before storing the engine indoor.

Pre-Operation Checks

Check the oil level

Lubricating oil:

- Engine lubricant oil is a major factor affecting engine performance and service life.
- The use of the lubricating oil free of cleaning agent or the lubricating oil for the two-stroke engine will shorten the life of the gasoline engine.
- The operating temperature range recommended for the gasoline engine is - 5°C-40°C.
- Use 4-stroke motor lubricant oil. 20W-40 is recommended in general, at all temperature use. Other viscosities shown in the chart may be used when the average temperature in your area is within the indicated range.

User Manual-Petrol Engine



Before Getting Started

Thank you for your purchase and use of our products. In order to avoid accidents or injury, **please read this manual carefully** before using the machine. After reading, preserve it for further reference. This manual is a part of the gasoline engine and should be transferred when the machine is resold.

Safety Labels



DANGER Indicates a hazard, if not avoided, can result in human injury or death.



WARNING Indicates a hazard, if not avoided, could result in human injury and/or property damage.

CAUTION

Indicates a hazard, if not avoided, might result in slight injury and/or property damage.



Please read and understand this owner's manual before operation of the engine to avoid accidents by familiarizing yourself with your engine's controls and safe operation procedures.

Safety Instructions

1. Please perform some pre-operation checks before operation to avoid human injury and equipment damage.
2. Keep the engine in good ventilated places at least 1 meter away from buildings and other equipment's during operation and keep the flammable substances

Tilling Depth	200 mm
Tine Diameter	240 mm
Transmission type	Chain
Gear	1
Rotation speed	143 rpm
Number of tines sets	6

KK-IC-205P:

Engine	Engine model	KK-PE4-203
	Max power (kW)	4.5
	Rated power (kW)	3
	Displacement (cc)	196
	Rated speed (r/min)	3600
Tilling Machine	Dimension(l x w x h) (mm)	1400×1000×980
	Net Weight (kg)	102
	Tilling width (cm)	92
	Tilling depth (cm)	≥10
	Working speed (m/s)	0.13-0.22
	Productivity (hm ² /h)	≥0.04
	Fuel consumption (kg/hm ²)	≤30
	Transmission	Gear transmission
	Connection	Directly shaft connection
	Tilling system	Design speed(r/min)
Max turning radius (mm)		180
Total blades		32 pcs
Blades type	Dry land blades	

KK-IC-207P:

Engine	KK-PE4-207
Displacement	196cc
Bore * Stroke	68*54mm
Rated power	4.5kW (6hp) / 3600RPM
Max Torque	11N.m/2500RPM
Fuel Tank	3.6 liters
Oil Tank	0.6 liters
Working Width	92 cm
Net Weight	15kgs

Note:

- KK-IC-200P/205P/207P models come with **FREE HEADLIGHT**.
- Product specifications are subject to change without prior notice.

Troubleshooting

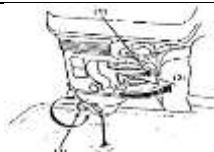
Problem	Probable cause	Solution
When the engine does not start:	Insufficient fuel	Fill the fuel
	Fuel valve is not in the ON position	Bring the fuel valve to ON position
	Engine switch is not in ON position	Bring the engine switch to ON position
	Petrol is not reaching the carburetor	Loosen the drain knob with the fuel valve ON. Fuel should flow freely. Retighten drain knob
		(1) FUEL VALVE (2) ON (3) DRAIN KNOB
There is no spark at the spark plug	a. Remove the spark plug cap. Clean any dirt from around the spark plug base, and then remove the spark plug. b. Install the spark plug in the plug cap. c. Turn the engine switch on. d. Grounding the side electrode to any engine ground, pull the recoil starter to see if sparks jump across the gap. e. If there is not spark, replace the plug.	

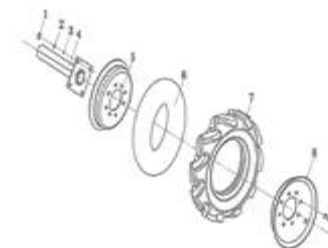

KK-PART NO	KK-PART NAME	Qty
G/B 8-01	Nut M10	8
G/B 8-02	Spring Washer10	8
G/B 8-03	Washer Flat 10	8
G/B 8-04	Wheel axle	1
G/B 8-05	Spoke(INSIDE)	1
G/B 8-06	Inner Tube	1
G/B 8-07	Outer Rubber Tyre 3.5-4	1
G/B 8-08	Spoke(OUTSIDE)	1
G/B 8-09	Bolt	4

2. Clutch has problem

Problem	Probable cause	Solution
Can't clutch	Clutch rod broken	Change or repair the clutch rod
	Clutch cable broken	Change the clutch cable
	Fork or gasket worn out	Change the gasket
	Fork pin bent or broken	Change
	Friction disk can't work	Change the friction disk

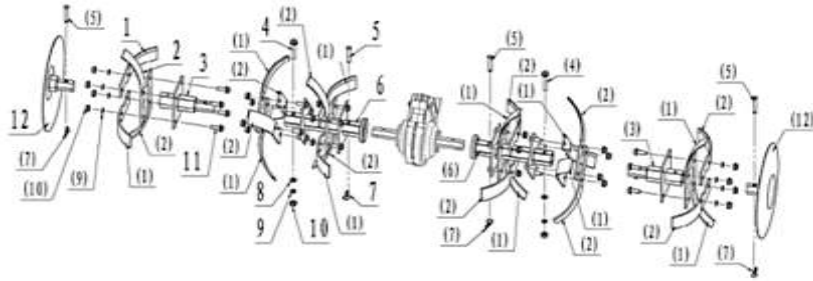

KK-PART NO	KK-PART NAME	Qty
G/B 7-01	Left Rotary Blade(DRY LAND)	12
G/B 7-01	Left Rotary Blade (WET LAND)	12
G/B 7-02	Right Rotary Blade(DRY LAND)	12
G/B 7-02	Right Rotary Blade (WET LAND)	12
G/B 7-03	Subsidiary Blade Holder Comp	2
G/B 7-04	Bolt M8x45	2
G/B 7-05	Pin Spindle 8x43	4
G/B 7-06	Primary Blade Holder Comp	2
G/B 7-07	Garther Spring B	4
G/B 7-08	Flat Washer 8	2
G/B 7-09	Spring Washer 8	26
G/B 7-10	Nut M8	26
G/B 7-11	Bolt M8 x 25	24
G/B 7-12	Side Disc	2

	Spring disk can't work	Change the spring disk
	Friction disk can't contact with bearing end side	use adjusting gasket
	Clutch broken	Change the clutch
Skid	Spring worn out and can't work	Change the spring
	Fork axle can't turn well	Clean it
	Clutch cable is not fitting well	Adjust the cable properly

3. Transmission box has problem

Problem	Probable cause	Solution
Gears are not functioning properly	Screw and round but at the back of main shaft is loosen.	Assemble main shaft well, and tighten the bolt at back.
Can't turn to needed forward gear	Block worn out	Change
	Driving umbrella gear is loose	Tighten bolts and nuts
	Spring of main shaft invalid Main shaft raid, screw of case back cover is loose	Change Tighten the screw
Reverse gear can't hang on	Reverse fork worn	Change
	Reverse cable can't work well Reverse axle is loose	Adjust or change Tight bolt at back of reverse axle
	Reverse fork block	Clean until it turns well
Reverse gear don't return	Reverse axle is loose and is causing gear block	Tighten bolt at back of reverse axle
	Spring on reverse axle can't work	Change the spring
	Reverse axle bend	Change the reverse axle
Reverse axle is loose	Bolt at back of reverse axle loosen	Tight
	Reverse axle and gear box not fixed well	Fix them properly
Gears make big noise	Umbrella axe, reverse axle bend	Replace
	Gears worn out seriously Umbrella reverse axle can't fixed well	Change them Fix them properly
Main shaft oil leak	Oil plug on main shaft invalid	Change the oil plug
Reverse axle leak oil	O-ring invalid	Change the O-rings
Clutch fork leak oil	O-ring invalid	Change the O-rings
Gear shift axle oil leak	O-ring invalid	Change the O-rings
Flange connection leak oil	Bolt is loose	Tighten the bolt
	Steel gasket broken	Change the gasket

4. Walking case has problem

Problem	Probable cause	Solution
Gear has big noise	Gears worn out or not assemble well	Change or assemble again
Gears block	Not assemble well	Assemble again
Over heat	Oil in case is little	Add oil
	Gears clearance too narrow	Assemble again
	Axle direction clearance is too small	Adjust the clearance
Transmission box connecting place leak oil	Connection bolts are loose	Tighten the bolts
Oil leak out	Gasket broken	Change the gasket
Output shaft sleeve outside leak oil	Oil seal broken	Change the oil seal
Output shaft sleeve inner hole leak oil	Sleeve broken	Change it
Drain hole leak oil	O ring broken	Change the O- rings
	Plug loosen	Tighten the plug
Case oil leakage	Case has some small hidden hole	Welding or paint it

5. Other problems

Problem	Probable cause	Solution
Blades broken	Hitting a stone or something hard	Change the blades
Cable broken	Worn out	Change the cable

Try to start the engine according to the instructions given above
If the engine still does not start, take the Inter-cultivator to an authorized dealer.

KK-PART NO	KK-PART NAME	Qty
G/B 5-01	Left Fender	1
G/B 5-02	Bolt M6x16	10
G/B 5-03	Washer 6x22x2	10
G/B 5-04	Rubber Sleeve	6
G/B 5-05	Nut M6	10
G/B 5-06	Right Fender	1
G/B 5-07	Connecting Plate	1

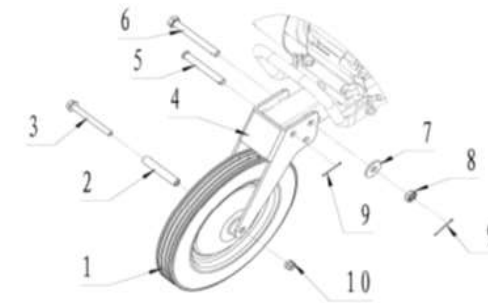

KK-PART NO	KK-PART NAME	Qty
G/B 6-01	Front Wheel	1
G/B 6-02	Sleeve (Front Wheel)	1
G/B 6-03	Bolt M8x75	1
G/B 6-04	Front Wheel Stand	1
G/B 6-05	Pin 10x75	1
G/B 6-06	Bolt M8x85	1
G/B 6-07	Washer 10 Flat	1
G/B 6-08	Nut M10	1
G/B 6-09	Cotter Pin 2x30	2
G/B 6-10	Nut M8	1

KK-PART NO	KK-PART NAME	Qty
G/B 4-09	V-belt Guard C	2
G/B 4-10	Bolt M8x16	2
G/B 4-11	V-belt Guard B	1
G/B 4-12	Driving Pulley Plate	1
G/B 4-13	Connecting Plate	1
G/B 4-14	Tensioner Spring	1
G/B 4-15	Tensioner Jointing	1
G/B 4-16	Torsion-bar Spring(Tensioner)	1
G/B 4-17	Washer Flat	1
G/B 4-18	Drive Pulley Plate	1
G/B 4-19	Bolt M6x10	1
G/B 4-20	V-belt Guard A	1
G/B 4-21	Bolt M6x12	2
G/B 4-22	Drive Pulley Comp	1
G/B 4-23	Bolt M6x20	1

Parts Diagram & List-Body-(KK-IC-200P)

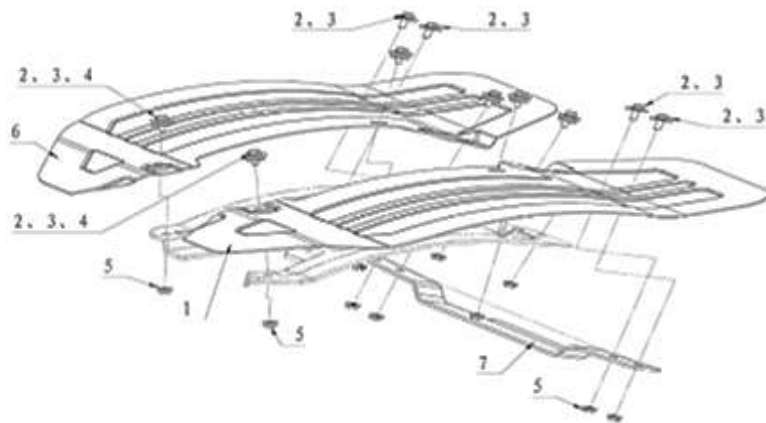
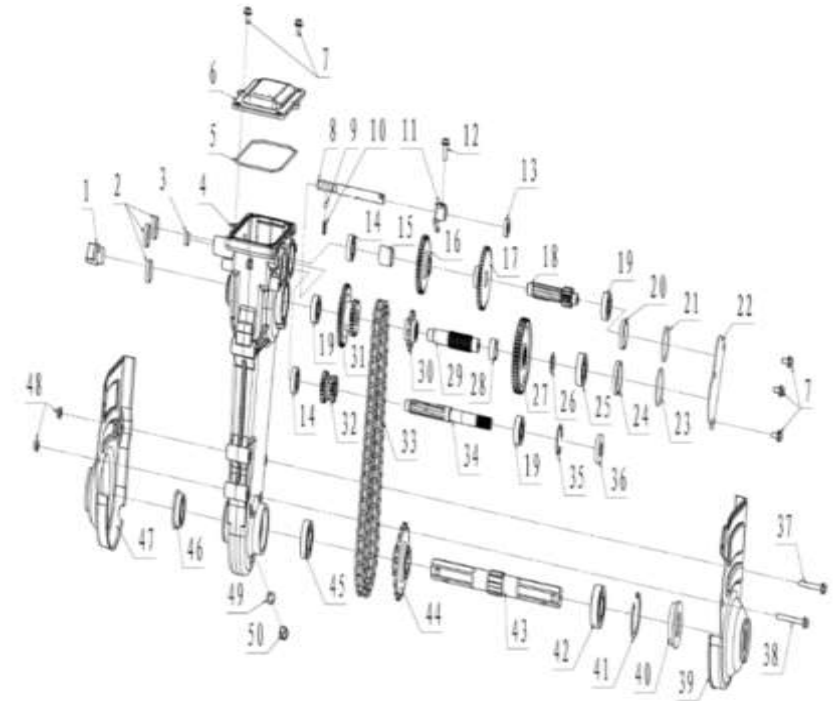

KK-PART NO	KK-PART NAME	Qty
G/B 1-01	Oil Hole Plug	1
G/B 1-02	Oil Plug A	3
G/B 1-03	Oil Plug B	1
G/B 1-04	Gear Box Housing	1
G/B 1-05	Seal Ring Of Top Cover	1
G/B 1-06	Top cover Comp Of Gear Box	1
G/B 1-07	Bolt M6x12	5
G/B 1-08	Shift Fork Shaft	1

KK-PART NO	KK-PART NAME	Qty
G/B 1-09	Steel Ball SΦ 6.35	1
G/B 1-10	Spring	1
G/B 1-11	Shift Fork	1
G/B 1-12	Bolt M6x20	1
G/B 1-13	Oil Seal 12x22x6	1
G/B 1-14	Bearing 6002	2
G/B 1-15	Bush F1	1
G/B 1-16	The 2nd Driven Gear	1
G/B 1-17	The 1st Driven Gear	1
G/B 1-18	Counter Shaft	1
G/B 1-19	Bearing 6202	3
G/B 1-20	Bush C	1
G/B 1-21	O-ring 39x2.6	1
G/B 1-22	Oil Stopper	1
G/B 1-23	O-ring 43.5x2.6	1
G/B 1-24	Bush D	1
G/B 1-25	Bearing 6203	1
G/B 1-26	Backup Plate	1
G/B 1-27	Driving Gear	1
G/B 1-28	Bush I	1
G/B 1-29	Driving Sprocket Shaft	1
G/B 1-30	Driving Sprocket	1
G/B 1-31	Double reverse gear	1
G/B 1-32	Two-throw Gear	1
G/B 1-33	Chain(50 Joints)	1
G/B 1-34	Main Shaft	1

KK-PART NO	KK-PART NAME	Qty
G/B 3-27	Bolt M8X 65	1
G/B 3-28	Bush 8X12X12	2
G/B 3-29	Bolt M8X 16	4

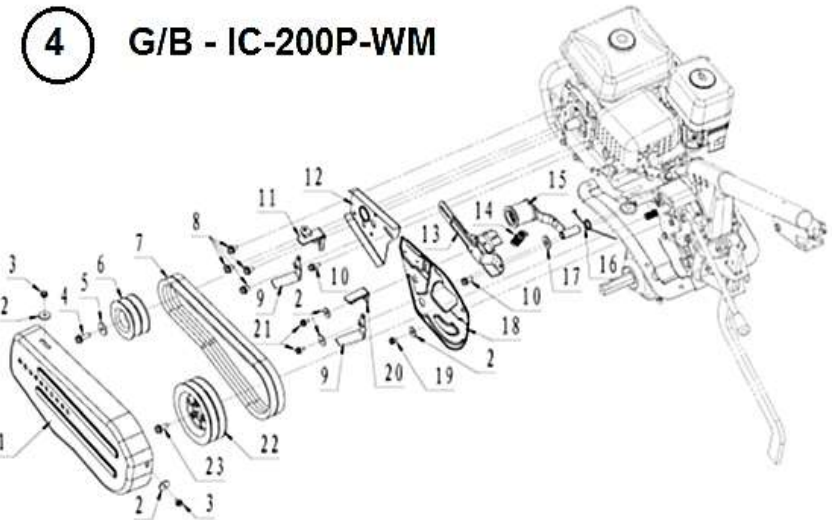

KK-PART NO	KK-PART NAME	Qty
G/B 4-01	Belt Protector	1
G/B 4-02	Washer 6x22x2 Flat	5
G/B 4-03	Bolt M6x10	2
G/B 4-04	Bolt M8x25	1
G/B 4-05	Washer 8x28x3 Flat	1
G/B 4-06	Driving Pulley	1
G/B 4-07	V-belt	2
G/B 4-08	Bolt M8x12	4

KK-PART NO	KK-PART NAME	Qty
G/B 3-01	Handrail	1
G/B 3-02	Engine Bracket	1
G/B 3-03	Bolt M8x40	4
G/B 3-04	Flat Washer 8x18x3	4
G/B 3-05	Spring Washer 8	9
G/B 3-06	Nut M8	4
G/B 3-07	Gasoline Engine	1
G/B 3-08	Flat Washer 8	5
G/B 3-09	Nut M8	5
G/B 3-10	Inner Fender	1
G/B 3-11	Nut M10	1
G/B 3-12	Spring Washer 10	1
G/B 3-13	Flat Washer 10	1
G/B 3-14	Pin Spindle	1
G/B 3-15	Hinge frame combination	1
G/B 3-16	Bolt M8x25	2
G/B 3-17	Bolt M8x30	4
G/B 3-18	Deep Furrowing Connecting Set	1
G/B 3-19	Garter Spring B	1
G/B 3-20	Bolt M8x20	2
G/B 3-21	Pin Spindle 8x43	1
G/B 3-22	Deep Furrowing Resistance part	1
G/B 3-23	Bolt M10x90	1
G/B 3-24	Garter Spring C	1
G/B 3-25	Pin (Tensioner)	1
G/B 3-26	Bolt M8X 70	1

KK-PART NO	KK-PART NAME	Qty
G/B 1-35	Circlip 35	1
G/B 1-36	Oil Seal 16x35x7	1
G/B 1-37	Bolt M6x45	1
G/B 1-38	Bolt M6x55	1
G/B 1-39	Gear Box Left Cover	1
G/B 1-40	Oil Seal A	1
G/B 1-41	Circlip 52	1
G/B 1-42	Bearing 6205	1
G/B 1-43	Driven Sprocket Shaft	1
G/B 1-44	Driven Sprocket	1
G/B 1-45	Bearing 6005	1
G/B 1-46	Oil Seal B	1
G/B 1-47	Gear Box Right Cover	1
G/B 1-48	Nut M6	2
G/B 1-49	Washer 10x16x2 (Drain Bolt)	1
G/B 1-50	Drain Bolt M10x1.25x12	1

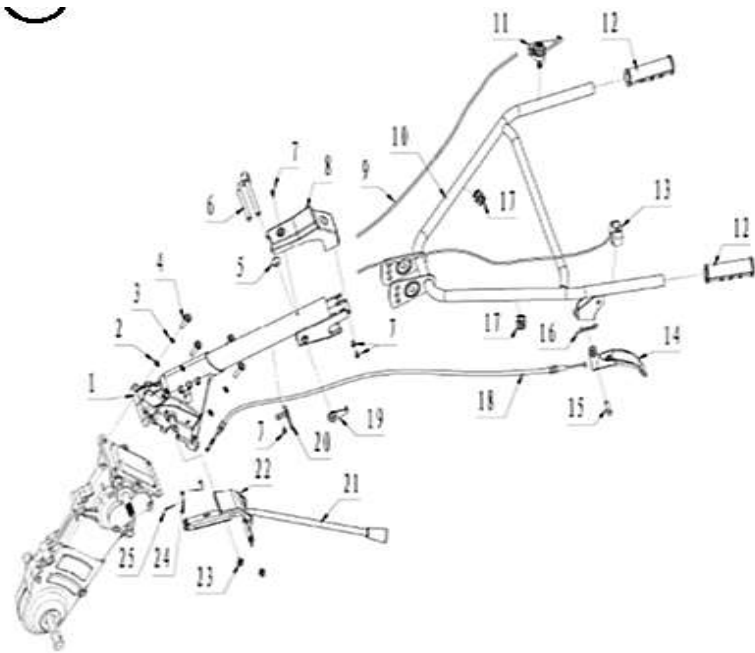

KK-PART NO	KK-PART NAME	Qty
G/B 2-01	Standing pipe Jointing	1
G/B 2-02	Flat Washer 8	4
G/B 2-03	Spring Washer 8	4
G/B 2-04	Bolt M8x25	4
G/B 2-05	Wimble Bush	1
G/B 2-06	Handle Adjuster Bolt	1
G/B 2-07	Screw ST 4.8x12	4
G/B 2-08	Inlet Cover	1
G/B 2-09	Throttle Cable Comp	1
G/B 2-10	Handle Comp	1
G/B 2-11	Throttle Handlebar	1

KK-PART NO	KK-PART NAME	Qty
G/B 2-12	Grip (Handle)	1
G/B 2-13	Shut Down Switch Comp	1
G/B 2-14	Clutch Handle	1
G/B 2-15	Pin 8x28	1
G/B 2-16	Clip F	1
G/B 2-17	Clip φ 22	2
G/B 2-18	Clutch Cable	1
G/B 2-19	Handle Adjuster Clamp	1
G/B 2-20	Loop	1
G/B 2-21	Shift Lever	1
G/B 2-22	Gear Position Indication Stand	1
G/B 2-23	Bolt M6x10	2
G/B 2-24	Pin 5 X 25	2
G/B 2-25	Clip 1.5 X 20	2

